

ATTENTION INSTALLER

**MAKE SURE THE FACILITY
MANAGER RECEIVES THIS
MANUAL AND WARRANTY
REGISTRATION IN BACK IS
FILLED OUT AND MAILED!**

**Product must be stored,
installed, and operated in a
DRY environment or damage
will occur and the WARRANTY
WILL BE VOIDED**



BACE

BALER AND COMPACTION EQUIPMENT



Owner/Operator Manual For Vertical Balers

“STRENGTH you depend on, QUALITY you count on”

Revision 2/22/2011

Table of Contents

Introduction	6
Warranty Statement	7
Procedures For Warranty	8-10
Pre Operation	
Positioning	11
Anchoring	11
Electrical	11
Hydraulic	11
Completion.	11
Electrical Requirements.	12
Maintenance Information	
Daily	13
Monthly.	13
Parts List	14
Lockout/Tagout Procedure	15
Emergency Operation	16
Baler Operation	
Normal Operation.	17
Bale Ejection Operation.	17
Equipment Diagram.	18-19
Trouble Shooting Guide	20
Appendices	
Appendices A (Electrical)	21-28
Appendices B (Hydraulic).	29-31
Warranty Registration.	33

Introduction

Congratulations on the purchase of your new BACE equipment. This equipment is designed to provide safe, trouble-free operation for many years. All BACE equipment exceeds A.N.S.I. Z245.5 safety standards.

This Owner/Operators Manual is presented to give the owner and or operator the necessary information to properly and safely operate the equipment. It also provides information for the routine maintenance and trouble-shooting.

If, after thoroughly reading this manual there are questions about the operation or repair of the equipment, call BACE @ 877-506-2223(BACE)

Our customer support hours are 8:00 am-5:00 pm EST Monday-Friday.

Manufacturers Limited Warranty

BACE, LLC (BACE) warrants parts and labor for a period of one (1) year in addition to parts replacement on major components for a period of two (2) years on its standard equipment and ten-years on the structure/frame. (Major components include cylinder, motor, pump and directional valve only) BACE's warranty is based on an 8-hour day and is devised accordingly. Following the completion of installation of the equipment at the end user's facility, and evidence by a signed and dated installation report, and warranty registration returned to BACE will substantiate the warranty. If no registration form is remitted or the installation is not provided by the factory, the warranty period shall be considered to start on the date of shipment. As limited herein, BACE warrants the equipment sold under this warranty to be free from defects in material and workmanship. This warranty does not apply to any defects caused by negligence, misuse, modifications, alterations, water damage to NEMA 12 components or accidents by purchaser or third parties. Warranty extends only to the original consumer and is non transferable. BACE reserves the right to void warranty if the provided warranty card was not fully completed and/or not returned to BACE **within 14 days** of Equipment Delivery. BACE reserves the right to determine if part(s) are genuine and/or defective. This warranty does not apply to any part that has been altered or repaired by any person not authorized by BACE, or which has been subjected to misuse, neglect or accident, or by any other cause beyond the control of the manufacturer.

This warranty excludes any obligation by BACE for loss of product, down time, or any other incidental or consequential damage incurred at any time.

BACE neither assumes nor authorizes anyone to assume for it any other obligation or liability in connection with such compactors or containers.

If BACE's installer/distributor are not on site at the time of equipment start-up, any labor or mileage obligation under this warranty will be voided.

THIS WARRANTY IS THE ONLY WARRANTY APPLICABLE TO BALERS, COMPACTORS AND CONTAINERS MANUFACTURED BY BACE AND IS EXPRESSLY IN LIEU OF ALL OTHER WARRANTIES, EXPRESSED OR IMPLIED, INCLUDING ANY IMPLIED WARRANTY OF MERCHANTABILITY OR FITNESS FOR A PARTICULAR PURPOSE.

LIMITED WARRANTY INCLUDES:

- Repair, or replacement with a similar part, any part of the product of our manufacture which is returned to us within thirty (30) days after discovery of the defect, properly identified and transportation charges prepaid, and not more than 3 years, after purchase by original consumer.
- Shall furnish without charge, a similar genuine part to replace any part of a product of its manufacture, which proves to be defective in normal use and service during this period.
- Shall supply service labor for defective parts or workmanship with the manufacturer's equipment within the warranty period at the published BACE flat rate for mileage and labor.

LIMITED WARRANTY EXCLUDES:

- Any part, which has been altered, redesigned or repaired by any person not authorized by BACE.
- Water damage from outside storage, installation or operation.
- Any defected part which is the result of neglect of proper maintenance, improper installation, misuse, accident vandalism, fire or any other cause beyond the control of the manufacturer
- Product of other manufacturers beyond such warranty as is made by such manufacturer is null and void from this warranty.
- Shipping and special handling charges to expedite part shipment.
- Maintenance instructions and proper cleaning instructions were neglected, which are determined by BACE.
- Ejector Chains
- Limit Switch adjustments
- **ALL OCC, V32 and 865 Models are warranted for 1 year parts and labor only (Frame 5 years).**
- ALL Single Phase Models are warranted for 1 year parts and labor only.

Procedures for Warranty Claims

PROCEDURES FOR WARRANTY CLAIMS FOR DEFECTIVE PARTS:

ALL THE FOLLOWING PROCEDURES MUST BE FOLLOWED ON ALL PART RETURNS DURING THE WARRANTY PERIOD. FAILURE TO COMPLY WITH THE FOLLOWING PROCEDURES WILL ABSOLVE BACE OF SUCH CLAIMS.

(SEE ATTACHED WARRANTY POLICY)

BACE CUSTOMER SERVICE: 877-506-2223(BACE)

Motors:

1. Once checked by a qualified technician who determines that no problems exist with fuses or wiring from incoming power source, then call BACE Service Department to notify us of the problem with the product model and serial number, and verify your warranty period and receive a warranty RGA number. We will then direct you to the nearest factory authorized motor diagnostic/repair facility.
2. If the factory facility determines that the problem is a factory defect, then the factory facility will replace the motor at no charge.
3. If it is determined that the motor problem was not due to a factory defect, then it will be the customer's responsibility to replace the motor.
4. BACE is not responsible for pick-up and delivery charges to the factory facility.

Hydraulic Cylinders:

1. Once checked by a qualified technician who determines that there is a problem with the cylinder, then call BACE Service Department to notify us of the problem with the product model and serial number, and verify your warranty period and receive a warranty RGA number.
2. BACE will at that time ship out a replacement cylinder from BACE or the cylinder manufacturer. Shipment will be normal freight rate, unless otherwise specified by the customer. For shipments other than normal freight (i.e. The determination of overnight shipping costs will be made solely by BACE.)
3. The customer is responsible for shipment of the defective cylinder, **within 30 days**, to BACE to determine the final warranty status.
4. In the event the cylinder is not received within the allotted time frame, then the customer will be billed the total amount of the replacement cylinder plus S & H.

All other parts:

1. Once checked by a qualified technician and determined that there is a problem with the part, then call BACE Service Department to notify us of the problem with the product model and serial number, verify your warranty period, and receive a warranty authorization number.
2. BACE will at that time ship out a replacement part from BACE or authorize the customer to purchase the part from an authorized distributor, factory warehouse. Shipment will be normal freight rate, unless otherwise specified by the customer. For shipments other than normal freight (i.e. The determination of overnight shipping costs will be made solely by BACE.)
3. It is the customer's responsibility to ship the defective part back to BACE **within 30 days** with the RGA#, at BACE's discretion.
4. If the part is not received within 30 days and or if the part does not pass warranty inspection, the customer will be invoiced for the part and will not be held responsible for any charges for the corresponding repair.
5. All labor and travel will be paid per BACE's flat rate schedule. The work required to replace any part must first be authorized by BACE. (See below for *Flat Rate Schedule*).

The invoice from the customer must be itemized to include model, serial number of unit, work performed, an BACE warranty authorization number, location of equipment, labor hours & mileage.

Flat Rate Schedule for Labor and Mileage:

1. In all cases of replacement of parts, repair of structural components the customer is required to call in to BACE Service Department for a "Warranty Authorization Number." In cases where the work has begun and will exceed the Flat Rate Schedule more than 5% of the original estimate, you will be required to contact the Service Department for approval. In cases where the hours exceed the original flat rate schedule and/or work not authorized with a Warranty Authorization Number, that claim on the excess will be denied. NO CREDIT will be allowed for labor hours spent on the inspection or diagnosis of equipment problems.
2. In cases of structural repair by welding, re-fabrication, or modification of an existing design, an official authorization must be obtained from the BACE Service Department prior to work. The request must have the model number, serial number, brief description or drawing of work to be done.
3. Flat Labor Rate for warranty claims, service is **\$65.00 per hour**.
4. Travel time (man and truck) will be paid at the rate of **\$.50 per mile**. (Mileage is limited to a maximum of 200 round trip miles.)

CAUTION: Only factory original replacement parts or equivalent should be used to insure proper operation of equipment.

**FAILURE TO COMPLY WITH ALL OF THE ABOVE PROCEDURES
WILL VOID ALL WARRANTY CLAIMS**

Parts Which Have Been Replaced:

1. In the event that a part fails during the first twelve month's of the baler's warranty, the replaced part will be warranted for one (1) year from the time of installation. The labor to replace this part will be covered for 90 days after installation or the remainder of the original machine warranty, whichever is longer.
2. In the event that a part fails during the "part's only" period of a baler's original warranty, the replaced part will have a one (1) year warranty and the labor to replace this part will be covered for 90 days after installation.
3. Replacement Parts will have a one (1) year parts only warranty.

CAUTION: Only factory original replacement parts or equivalent should be used to insure proper operation of equipment.

**FAILURE TO COMPLY WITH ALL OF THE ABOVE PROCEDURES
WILL VOID ALL WARRANTY CLAIMS**

Pre-Operation

The Vertical Baler requires up to 10' x 12' of clear floor space and up to 14' of ceiling height for proper installation and operation.

This space should always be kept clear of materials which could interfere with the safe operations of the baler.

BALER IS SUPPLIED WITH NEMA 12 WATER RESISTANT CONTROLS AND MUST BE STORED, INSTALLED AND OPERATED IN A DRY ENVIRONMENT OR DAMAGE MAY OCCUR AND WARRANTY WILL BE VOIDED.

(Optional NEMA 4 Water Proof controls and Weather covers are available)

POSITIONING

Positioning the vertical baler so that the sufficient room is available for proper and safe operation. The back of the baler should be placed no less than 24 inches from any structure to allow room to insert wires and tie of the bale. Also, enough room in front of the baler must be present to allow the chamber door to swing fully open so the finished and tied bale can be ejected. **MUST BE STORED, INSTALLED AND OPERATED IN A DRY ENVIRONMENT OR DAMAGE MAY OCCUR.**

ANCHORING

BACE recommends mounting the baler on a pad of steel reinforced concrete with a minimum of 3000 psi capacity. The pad should be at least 4 inches deep. The baler should be anchored to the pad with 4 (**6 on S865 Models**) $\frac{3}{4}$ " anchor bolts 5" to 6" long. To allow for construction variances, the holes should be drilled after locating the baler in the desired position.

ELECTRICAL

A lockable fused disconnect switch (customer furnished) must be installed within 5 feet, and in the line of site of the baler electrical enclosure. This disconnect must be sized in accordance with the baler motor and voltage. (See Figure 1.1 for Single Phase and Figure 1.2 for 3 Phase)

HYDRAULIC

Check for any hydraulic oil leaks and make sure that all hoses are tight.

Final Checklist before operating your baler for the first time

*In some cases the machine is shipped with the cylinder lowered. Inspect to make sure cylinder is bolted to the frame of the machine **before** the machine is operated.*

Make sure all appropriate safety decals are present and in their proper locations.

Check the baler motor is wired for the correct voltage.

Check that motor rotation is clockwise.

Check that the motor starter has the correct thermal overloads for the installed voltage and that the transformer is wired for the correct voltage.

Electrical Requirements

Figure 1.1 Single Phase Motor Voltage

Motor	Voltage	Full Load Amps	Power Supply Required
2HP	110V	21	30
2HP	208V	13	30
2HP	220V	10.8	20
10HP	220V	50	100

Figure 1.2 Three Phase Motor Voltage

Motor	Voltage	Full Load Amps	Power Supply Required
10HP	208V	30	60
10HP	230V	28	60
10HP	480V	14	30
10HP	575V	11	30
15HP	208V	46	80
15HP	230V	41	80
15HP	480V	20	40
15HP	575V	17	40
20HP	208V	59	100
20HP	230V	54	100
20HP	460/480V	27	50
20HP	575V	22	50
(4) 10HP	208V	30.8/Motor	150
(4) 10HP	230V	28/Motor	150
(4) 10HP	460/480V	14/Motor	100
(4) 10HP	575V	11/Motor	50

Maintenance Information

Note: BACE recommends that you maintain a record of your preventative maintenance inspections. Failure to perform regular maintenance may result in damage to the Baler.

DAILY:

- ✓ Inspect for Oil Leaks.
- ✓ Inspect Oil Level.
 - **Note:** With the Platen Up, Hydraulic Tank should be $\frac{3}{4}$ full.
- ✓ Inspect the following for Loose, Damaged or Missing:
 - Bolts
 - Ejector Chains
 - Limit Switches
 - Welds
 - Safety Decals
 - Guards
 - E-Stop Switch
- ✓ Inspect for Debris:
 - Remove All Debris Around Baler
 - Remove All Debris From Top Of Platen

MONTHLY:

- ✓ Check for Signs of Wear:
 - Inspect Cylinder for Scars on Rod
 - Oil Leaks
 - Mounting Bolts are Tight
 - Door Hinges/Hand Wheel for excessive play
 - UHMW on Gate and Platen for *abnormal* wear
 - Lubricate moving parts (Sprockets, Chains, Hinges and Turnbuckle)(Repair or Replace if Required)
- ✓ Check Hydraulic Oil.
 - Should not be Cloudy or Milky in appearance(Replace if Required)
- ✓ Check Air Breather/Filter.
 - (Replace if Required)
- ✓ Check Oil Filter; located in the Hydraulic tank under the access panel.
 - Change Every 12 Months
- ✓ Check Hydraulic Fittings and Connections.
 - (Repair or Replace as Required)

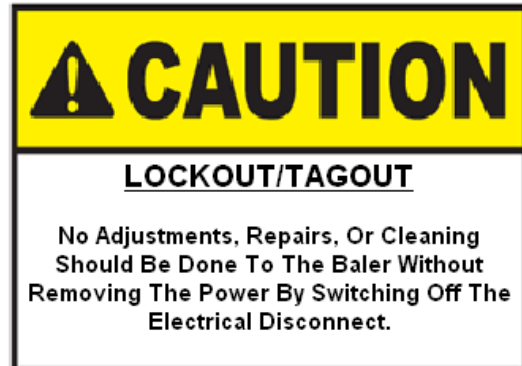

Parts List

POWER UNITS

BWG13015 15HP/3PH/208/230/460 WEG MOTOR
BWG13020 20HP/3PH 208/230/460 WEG MOTOR
BBA15540 15HP/3PH/575V BALDOR MOTOR
BBA16000 20HP/3PH/575 V BALDOR MOTOR
BNA60501 GEAR PUMP
BNA34505 DIRECTIONAL VALVE
BNK20040 3/4 A-B PORT SUB PLATE
BSU10000 RELIEF VALVE
BPD11200 4000PSI GAUGE
BUC21000 SUCKTION STRAINER 1"
BME12276 PRESSURE SWITCH
BMC12000 TRANSFORMER
BAB900130 CONTACTOR (MOTOR STARTER)
BAB900452 CONTACTOR OVERLOAD
BAA12125 RELAY
BID14000 RELAY BASE
BTE12000 PUSH BUTTON, GREEN
BTE12200 PUSH BUTTON, YELLOW
BTE13000 PUSH BUTTON, E-STOP
BAB13575 MAIN DOOR SWITCH
BAB13600 ANSI SWITCH
BAB1358 SAFETY GATE SWITCH
BTE83600 ON/OFF KEY SWITCH 2 POS
BTE10000 RESET BUTTON
BHBC BREATHER CAP

CYLINDER

B63035 6" X 30" X 3.5"
B64835 6" X 48" X 3.5"
B7605 7" X 60" X 5"

HARDWARE PARTS

BECHVA EJECTOR CHAIN ASSYEMBLY
BECQLVA EJECTOR CHAIN QUICK LINK
BMGHVA MAIN GATE HANDLE
BWTVA WHEEL TURNBUCKLE
BGGTVA GATE GUIDE TUBE ASSEMBLY (EACH)
BMGAVA MAIN GATE ASSEMBLY
BUHMWVA UHMW KIT
BSMBVA SWITCH MOUNTING BRACKET

Lockout/Tagout



BALER LOCKOUT TAGOUT PROCEDURE

This procedure establishes the minimum requirements for the lockout of a baler for service. It shall be used to ensure that the machine is isolated from all potentially hazardous energy, and locked out before employees perform any servicing or maintenance activities where the unexpected energization or start-up could cause serious injury or fatality due to the electrocution or due to entrapment in moving parts. This procedure should be performed only by an authorized, qualified electrician.

1. Before locking baler out for service or repair, locate which breaker or disconnect applies to the baler to be locked out. Notify all affected employees that a lockout system is going to be utilized and the reason therefore.
2. If the machine or equipment is operating, shut it down by the normal stopping procedure.
3. Lock out the disconnect or breaker that controls the baler. If locking out a breaker use a double-pole breaker lockout and lock.
4. Lockout the energy isolating devices with assigned individual locks. If more than one person is servicing the baler, then a hasp with a lock for each service person shall be used.
5. After ensuring that no personnel are exposed, and as a check on having closed the appropriate breaker or disconnect, operate the start button to make certain the baler will not operate. Then push the stop button. The baler is now locked out.
6. After the servicing and/or maintenance is complete and the equipment is ready for normal; production operations, check the area around the machines or equipment to ensure that no one is exposed.
7. After all tools have been removed from the baler and employees are in the clear, remove the lockout device. Operate the start button to restore energy to the baler.

Emergency Operation

Should an emergency occur while operating the baler, press the **RED STOP BUTTON** and the baler will terminate all functions and shut down.

EVERYONE AUTHORIZED TO OPERATE THE BALER SHOULD KNOW THIS EMERGENCY PROCEDURE.

CAUTION! IMPORTANT! READ BEFORE OPERATING THE BALER.

BACE Balers meet and exceed all safety standards set by A.N.S.I. Although BACE has included many safety features in the design and construction of the baler, safe operation of the equipment depends on the operator's adherence to the certain guidelines. To prevent accidents to the personnel or damage to the baler, the operator **MUST NEVER VIOLATE ANY OF THE FOLLOWING SAFETY PRECAUTIONS.** It is the client's responsibility to ensure these guidelines are known and followed by all operators of the baler.

NOTE: Publication of these safety precautions does not imply or represent an inclusive list.

NEVER place hands or arms in the baler while it is operating.

NEVER stand behind the baler while it is operating.

NEVER climb in or on the baler, nor perform any maintenance/repairs unless the power is disconnected and locked out.

NEVER allow anyone except qualified electrical or hydraulic repair persons to work on the equipment.

NEVER disable any safety switch.

NEVER overload the baling chamber.

NEVER place concrete, heavy steel plate or castings, explosive materials, liquids, nor hazardous waste in the baler.

NOTE: Hydraulic oil is the primary element of power transmission on the baler. Remember that hydraulic systems can remain pressurized even after the motor has stopped and the power is disconnected.

Baler Operations

BALING OPERATIONS:

1. Close and lock main door by tightening hand wheel (ratchet on XHD) lock.
2. Open Safety Gate and Load Material to be baled.
3. Pull Down Safety Gate.
4. Turn Key Switch to ON Position.
5. Press the Down Push Button, Platen will automatically cycle.



Repeat Steps 1 through 5 until Bale is formed, Platen will automatically stop in the DOWN position when bale is full, except on OCC Models where baler is shut down manually at Full Bale. Some balers also have an OPTIONAL Full Bale Light that will come on at the same time the Platen automatically stops.

TIE-OFF AND EJECT BALE:

6. Open Main Door when Platen stops in down position.
7. Insert Baling Wires through the floor slots.
8. Insert Baling Wires back through the Platen slots ***from the rear of the Baler.***
9. Tie-Off Baling Wires located in the front of Baler.
10. Located at the **REAR** of Baler, hook up the Ejector Chain (s) to the Red Platen Brackets.
11. Stand clear of the front of Baler and push the UP push button. (Notice that the Bale will automatically eject.)
12. Remove bale.
13. Close main chamber door and tighten door hand wheel (ratchet on XHD) lock. (DO NOT LOAD NEW MATERIAL AT THIS POINT. WAIT UNTIL STEP 14 IS COMPLETE.)
14. Close safety gate and run Platen down to automatically remove ejector chain (s) from Red Platen Brackets. ***Skip this step on OCC Models. Ejector Chains must be removed at this point manually and returned to the storage peg.***

Ready to repeat steps 1 through 14 for next Bale.



Equipment Diagram

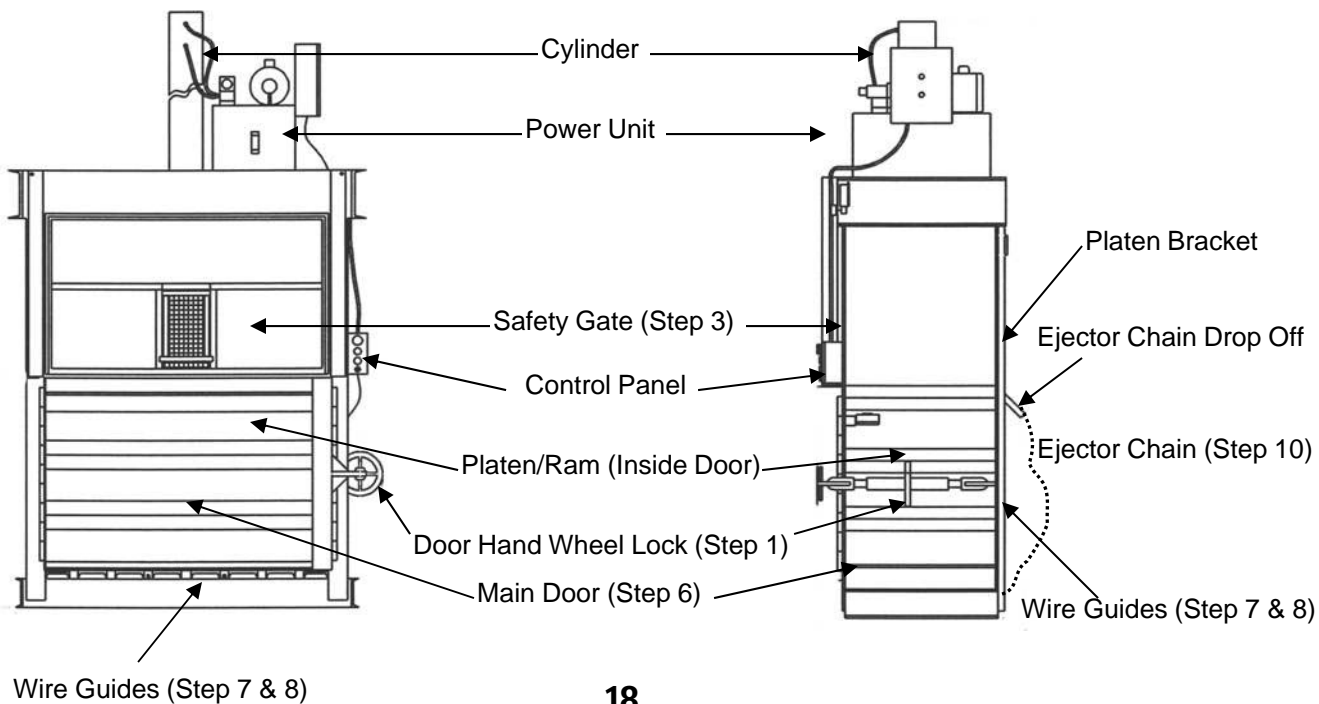
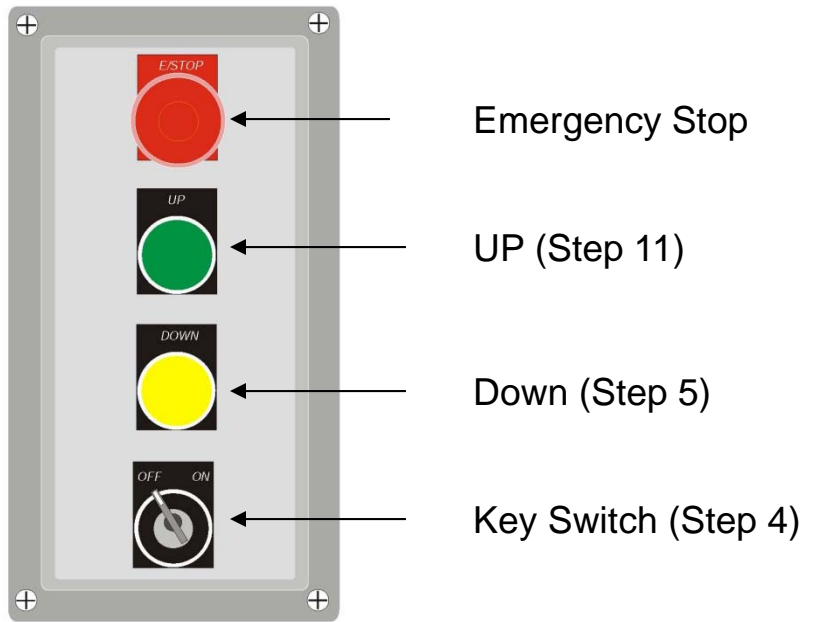

Equipment Diagram XHD Model

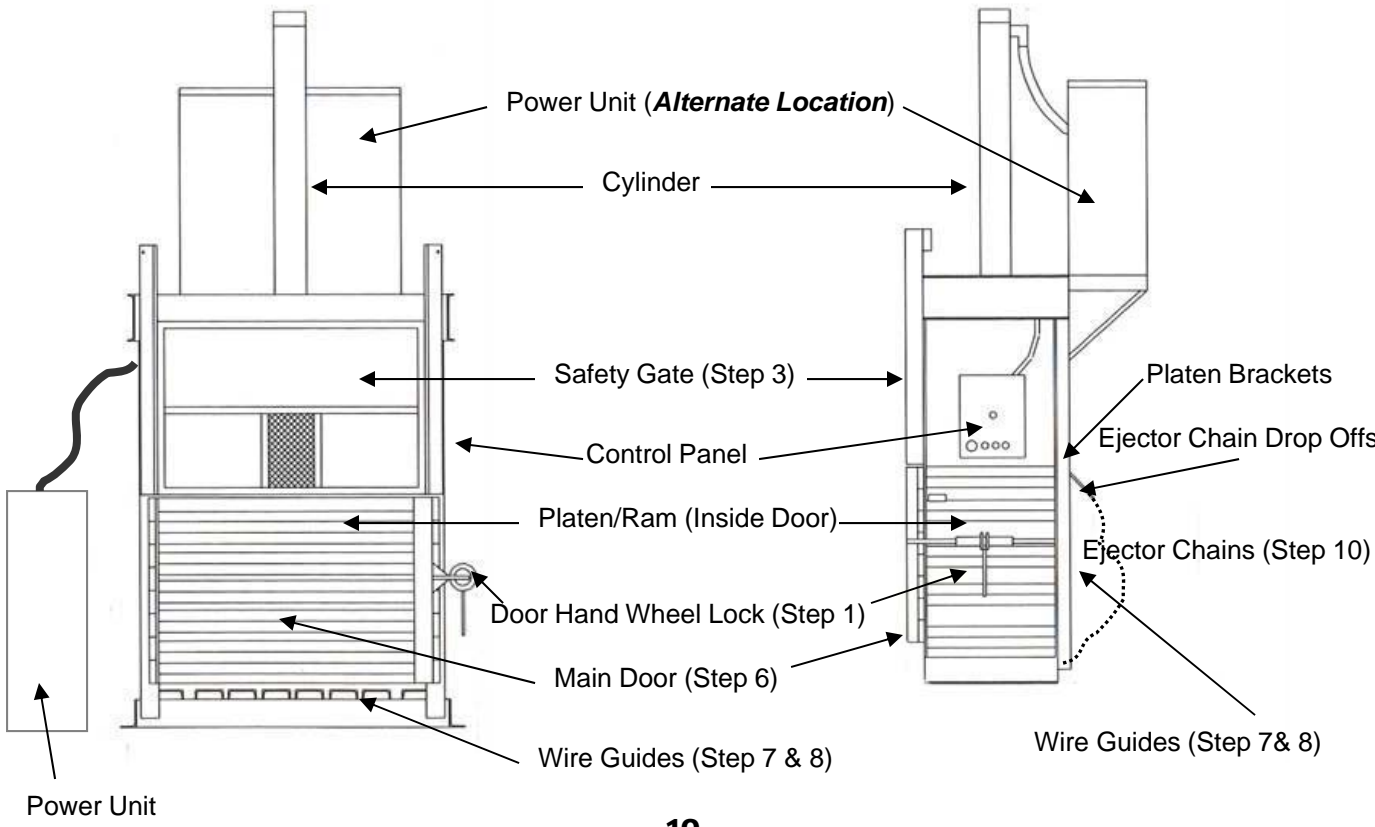
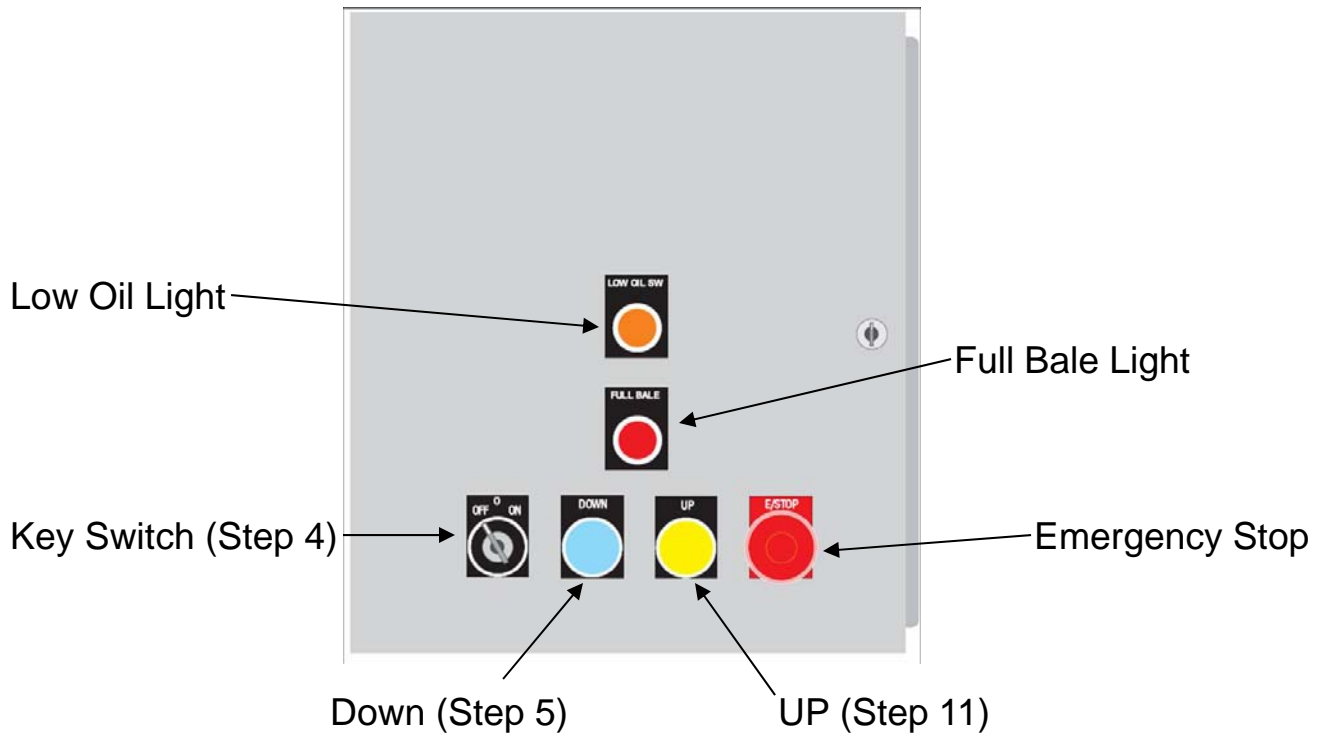

Trouble Shooting Guide

NOTE: ONLY FACTORY AUTHORIZED SERVICE REPRESENTATIVES SHOULD MAKE ADJUSTMENTS OUTSIDE THE SCOPE OF THIS MANUAL.

MOTOR WILL NOT OPERATE:

- Check fused disconnect.
- Check motor starter thermal overloads. Reset if necessary.
- Check motor starter coil.
- Check that safety gate switch is working properly.
- Check that main chamber door is **fully closed**.

MOTOR RUNS BUT PLATEN DOES NOT MOVE

- Check for proper motor rotation. (clockwise from the fan end)
- Check the directional valve for proper operation.
- Check the pressure switch.
- Check the relief valve for proper adjustment.
- Check the hydraulic fluid level. (Some may have Optional Low Oil Light)

BALER WILL NOT OPERATE IN AUTOMATIC MODE (OPTIONAL)

- Check loading door photocells.
- Check contact blocks on rear of mode selector switch for binding.

BALE WEIGHTS ARE LOW

- Check for proper system pressure.
- Check for proper relief valve adjustment.
- Check for proper pressure switch adjustment.
- Check that baler is achieving full bale status. See "Operating Instructions."

BALE SHIFTS ERRATICALLY

- Check for proper system pressure.
- Check for proper pressure switch adjustment
- Check relays and bases for signs or arcing. (Does not apply to XHD Models)
- Check directional valve.

BALER MAKES EXCESSIVE NOISE

- Check hydraulic fluid level.
- Check for water or air in hydraulic fluid.
- Check oil filter and suction lines components for tightness.
- Check motor fan cover for damage.
- Check that bolts are tight on press head UHMW wear guides.



12 11 10 9 8 7 6 5 4 3 2 1

CUSTOMER TO SUPPLY AND INSTALL INCOMING SERVICE DISCONNECT AND BRANCH CIRCUIT OVERCURRENT PROTECTION IN ACCORDANCE WITH CURRENT EDITION OF N.E.C. (SEE THE CIRCUIT BREAKER CHART)

OVERLOAD REPLACEMENT CHART			
HP	208V	230V	460V
15HP	48A	42A	21A

CIRCUIT BREAKER CHART	
208V/60Hz/3PH/100A CIRCUIT BREAKER	
230V/60Hz/3PH/80A CIRCUIT BREAKER	
460V/60Hz/3PH/40A CIRCUIT BREAKER	

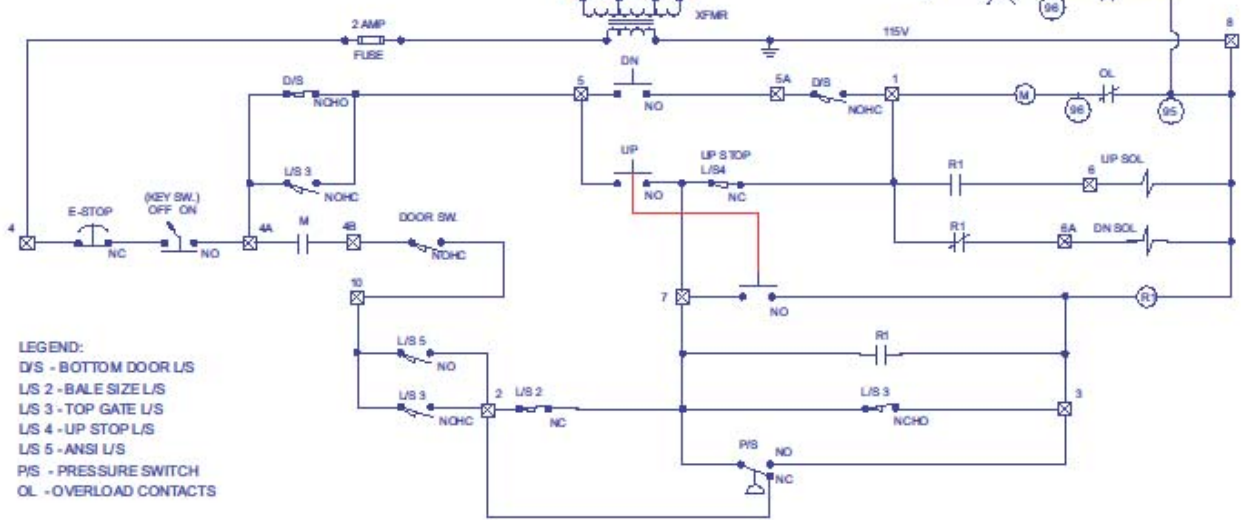
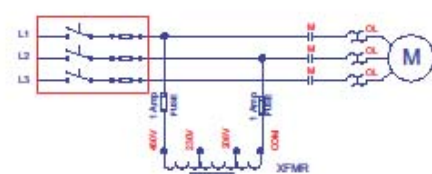

LEGEND:
 D/S - BOTTOM DOOR L/S
 L/S 2 - BALE SIZE L/S
 L/S 3 - TOP GATE L/S
 L/S 4 - UP STOP L/S
 L/S 5 - ANSI L/S
 P/S - PRESSURE SWITCH
 OL - OVERLOAD CONTACTS

REVISIONS

ZONE	REV	DESCRIPTION	DATE	APPROVED	APP BY:

TITLE: ELECTRIC SCHEMATIC
 MODEL NO: HE15250-99
 DATE: 01/15/05
 SHEET: 1 OF 1

HYDROLEC Inc.
 5050 Steep Ave.
 JACKSONVILLE, FL 32218
 Phone: (904) 370-3778

12 11 10 9 8 7 6 5 4 3 2 1

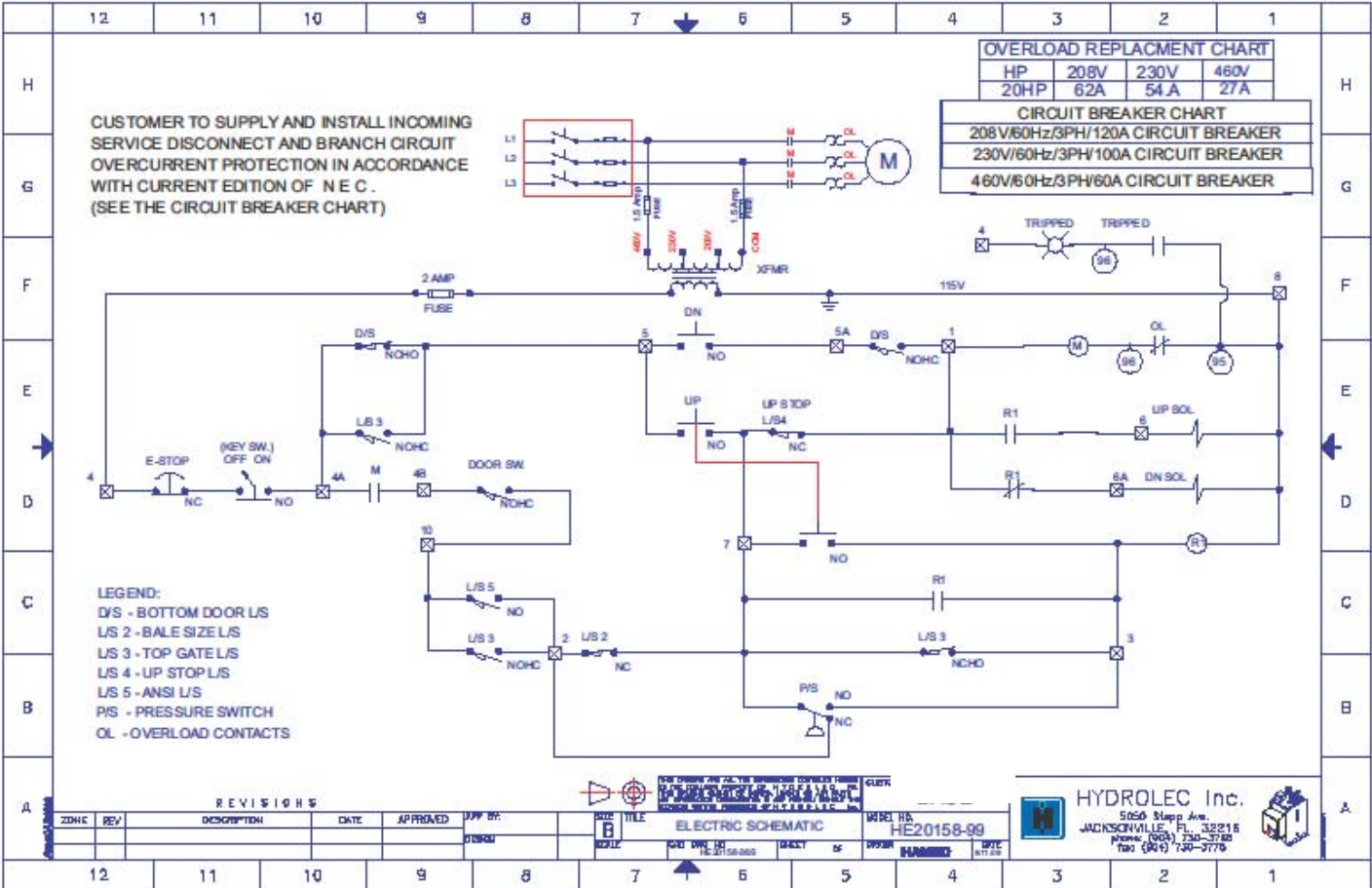

OVERLOAD REPLACEMENT CHART			
HP	208V	230V	460V
10HP	32A	28A	14A

CIRCUIT BREAKER CHART	
208V/60Hz/3PH/60A	CIRCUIT BREAKER
230V/60Hz/3PH/60A	CIRCUIT BREAKER
460V/60Hz/3PH/30A	CIRCUIT BREAKER

CUSTOMER TO SUPPLY AND INSTALL INCOMING SERVICE DISCONNECT AND BRANCH CIRCUIT OVERCURRENT PROTECTION IN ACCORDANCE WITH CURRENT EDITION OF N.E.C. (SEE THE CIRCUIT BREAKER CHART)

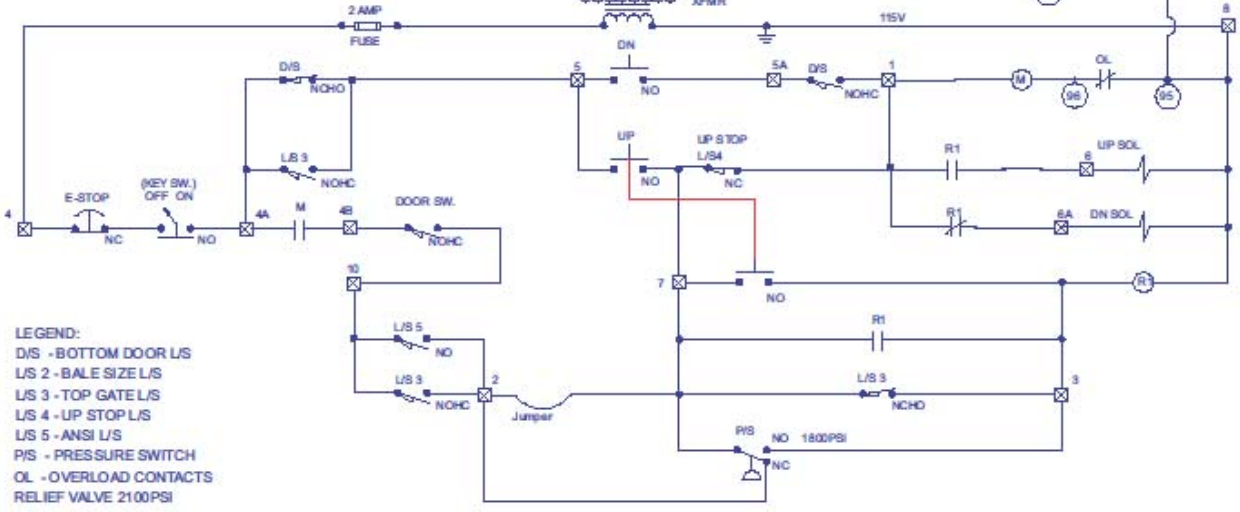
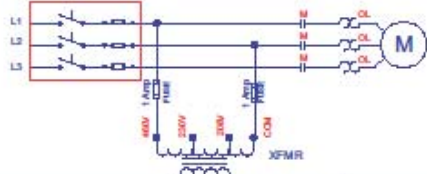

LEGEND:
 D/S - BOTTOM DOOR L/S
 L/S 2 - BALE SIZE L/S
 L/S 3 - TOP GATE L/S
 L/S 4 - UP STOP L/S
 L/S 5 - ANSI L/S
 P/S - PRESSURE SWITCH
 OL - OVERLOAD CONTACTS
 RELIEF VALVE 2100PSI

REVISIONS

ZONE	REV	DESCRIPTION	DATE	APPROVED	DRAWN BY
12	11				
10	9				
8	7				

HYDROLEC Inc. logo and title block information including 'ELECTRIC SCHEMATIC' and 'HE100070-99'.

HYDROLEC Inc. 5056 Slapp Ave. JACKSONVILLE, FL 32218
 Phone: (904) 730-3780 Fax: (904) 730-3775

ELECTRICAL SCHEMATIC – 10HP -SUBMERSIBLE

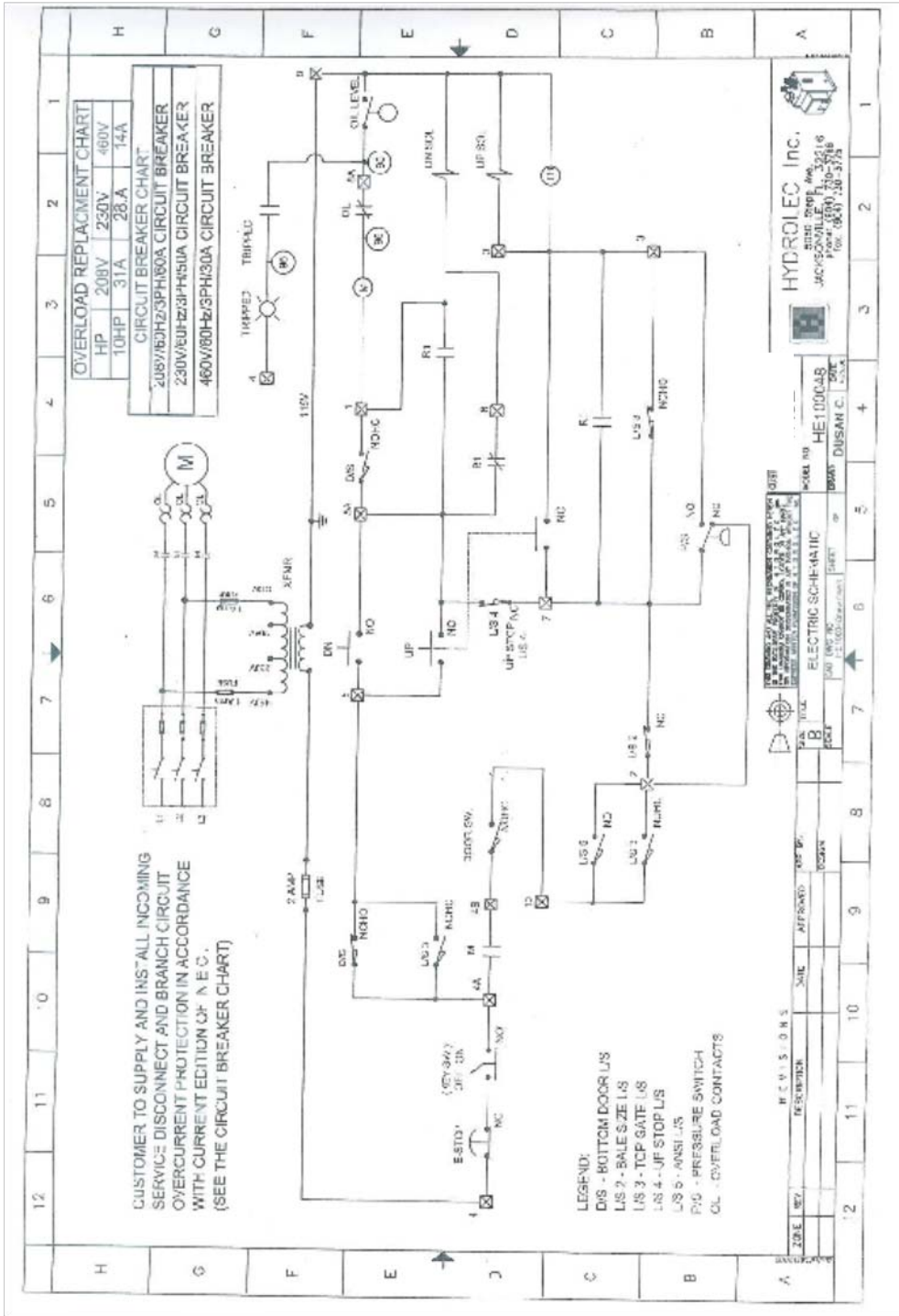

ELECTRICAL SCHEMATIC – 10HP -3PHASE

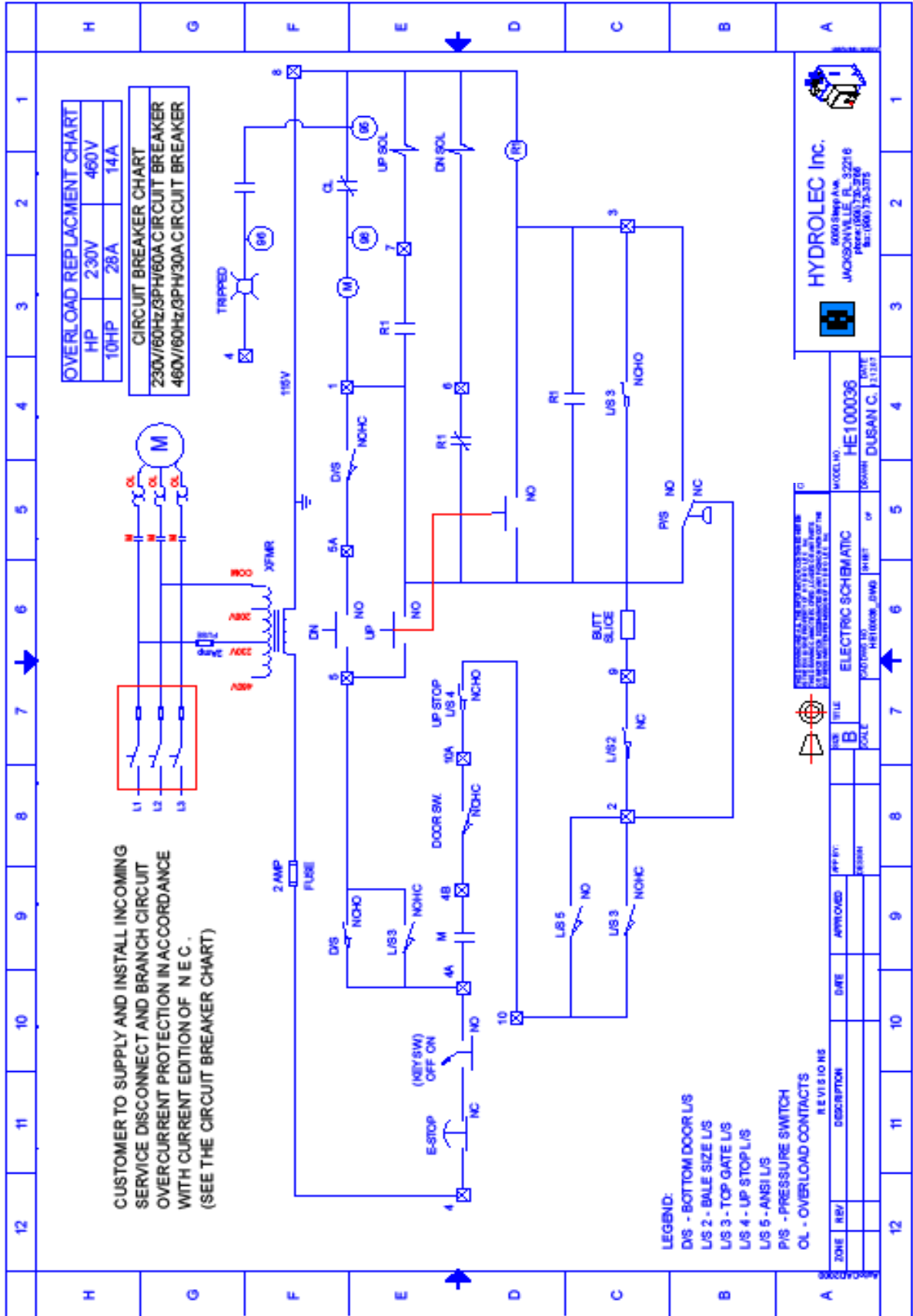

ELECTRICAL SCHEMATIC – 20HP-XHD

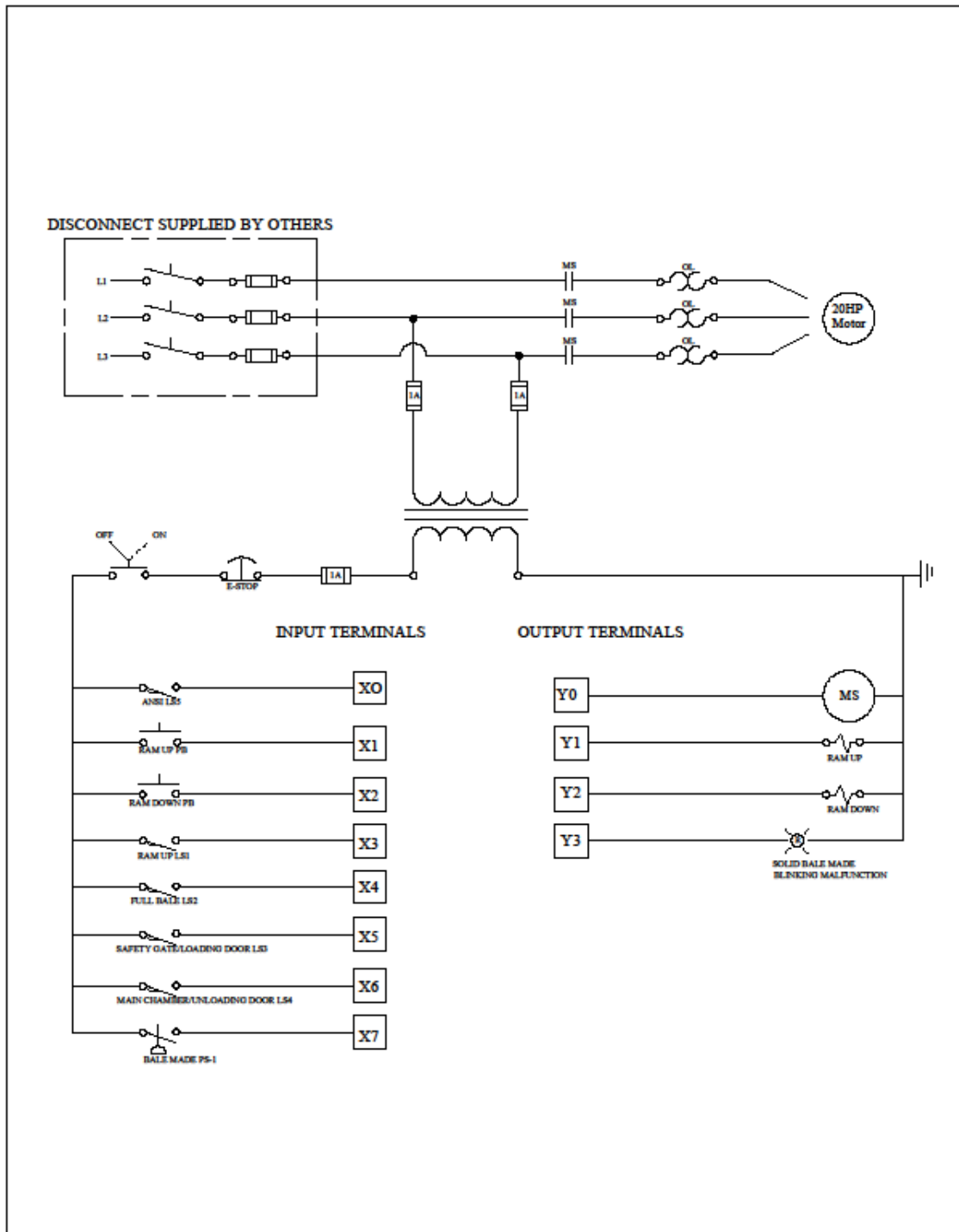

ELECTRICAL SCHEMATIC – 40HP

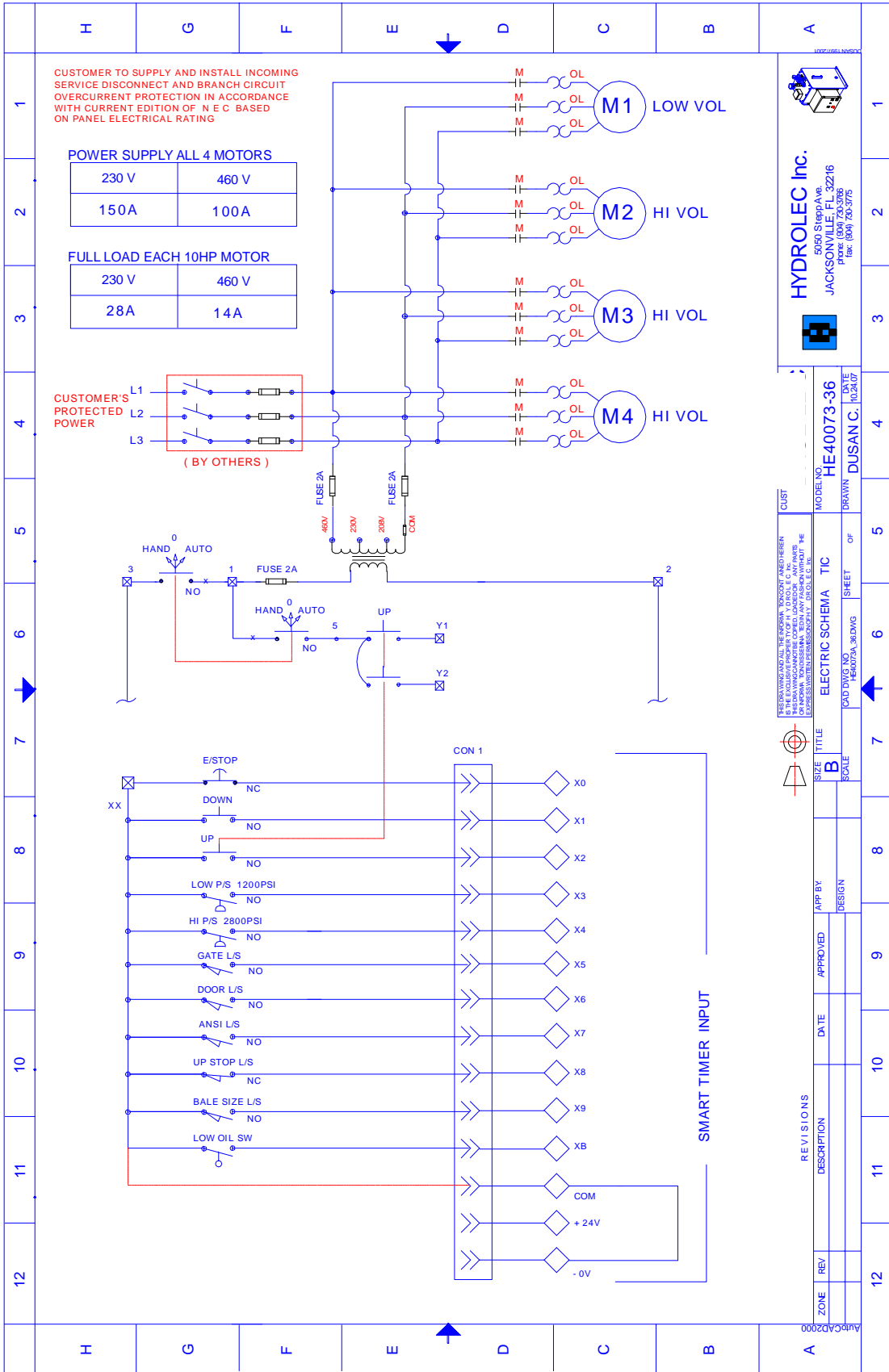

ELECTRICAL SCHEMATIC – 40HP-Cont.

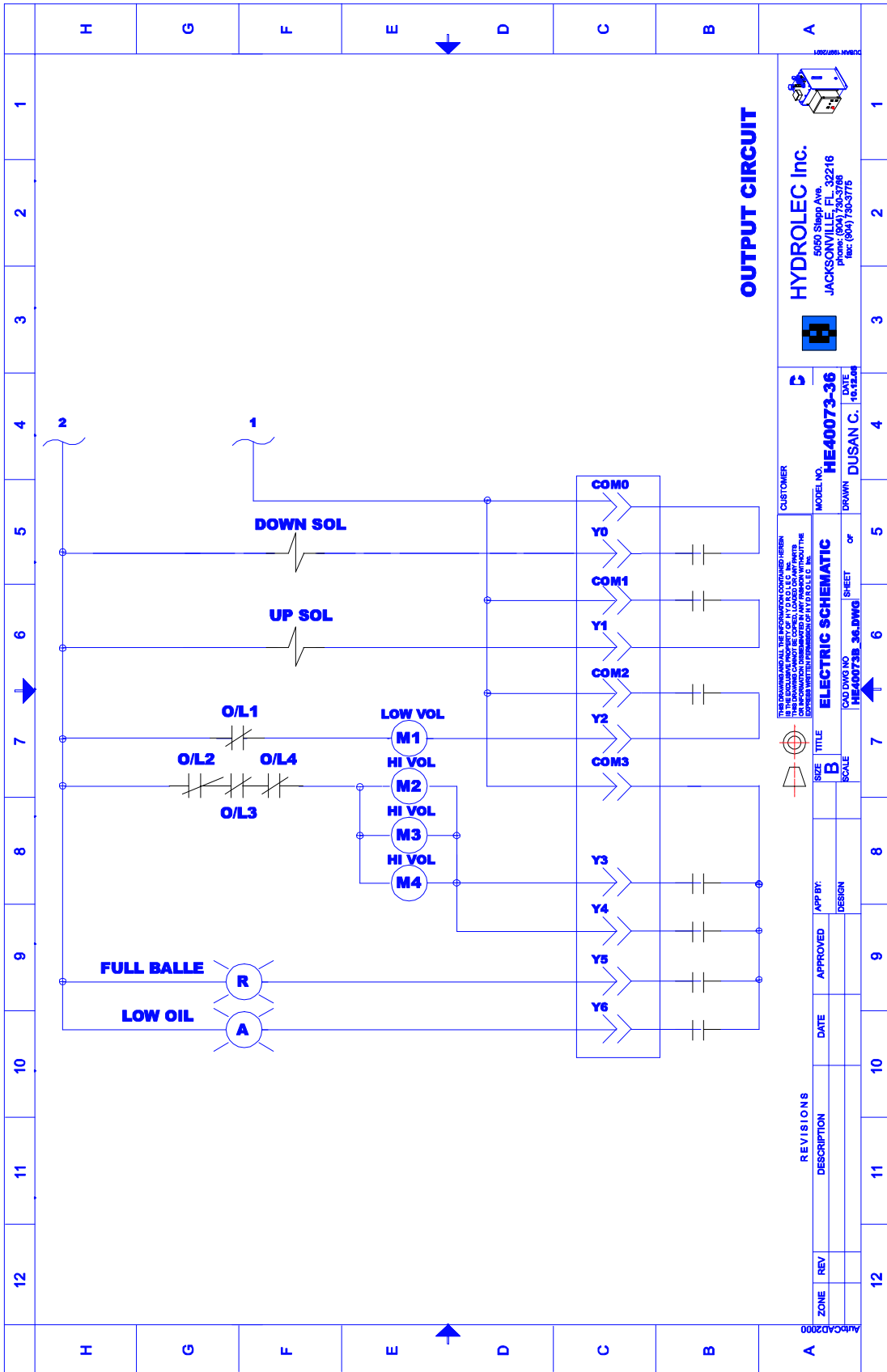

HYDRAULIC SCHEMATIC – ALL – EXCEPT 40HP/20HP-XHD

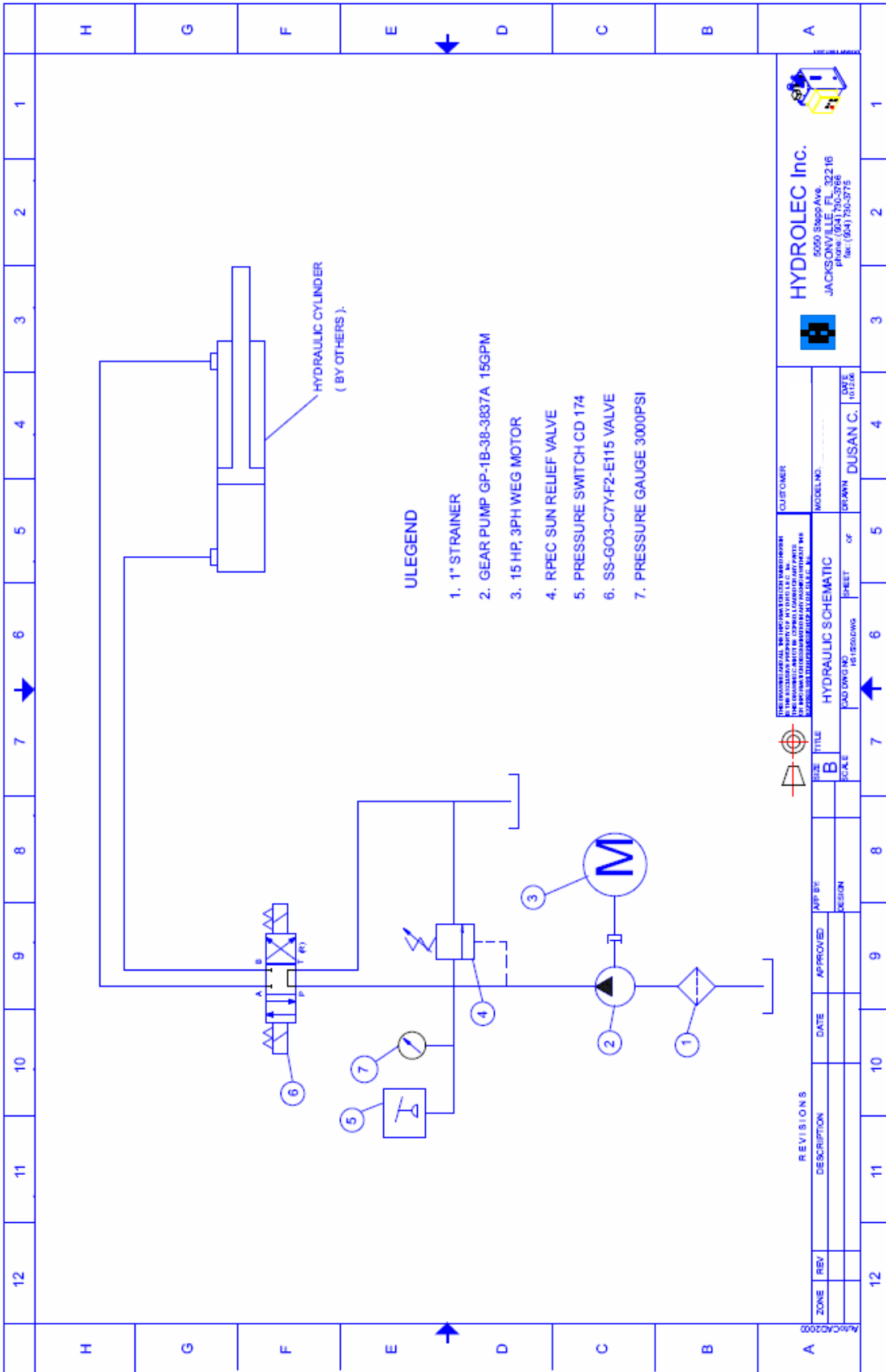

ULEGEND

1. 1" STRAINER
2. GEAR PUMP GP-1B-38-3837A 15GPM
3. 15 HP, 3PH WEG MOTOR
4. RPEC SUN RELIEF VALVE
5. PRESSURE SWITCH CD 174
6. SS-G03-C7YF2-E115 VALVE
7. PRESSURE GAUGE 3000PSI



HYDROLEC Inc.
 5200 Sisco Ave. 32216
 JACKSONVILLE, FL
 Phone: (904) 750-3788
 Fax: (904) 750-3775



CUSTOMER
 MODELING: _____
 DRAWN: DUSAN C.
 DATE: 10/10/06

HYDRAULIC SCHEMATIC
 SHEET 1 OF 1
 DOWNSIDE INDUSTRIES

TITLE
 B
 SCALE

APP BY
 DESIGN

APPROVED

DATE

REVISIONS

DESCRIPTION

REV

ZONE

HYDRAULIC SCHEMATIC – 20HP - XHD

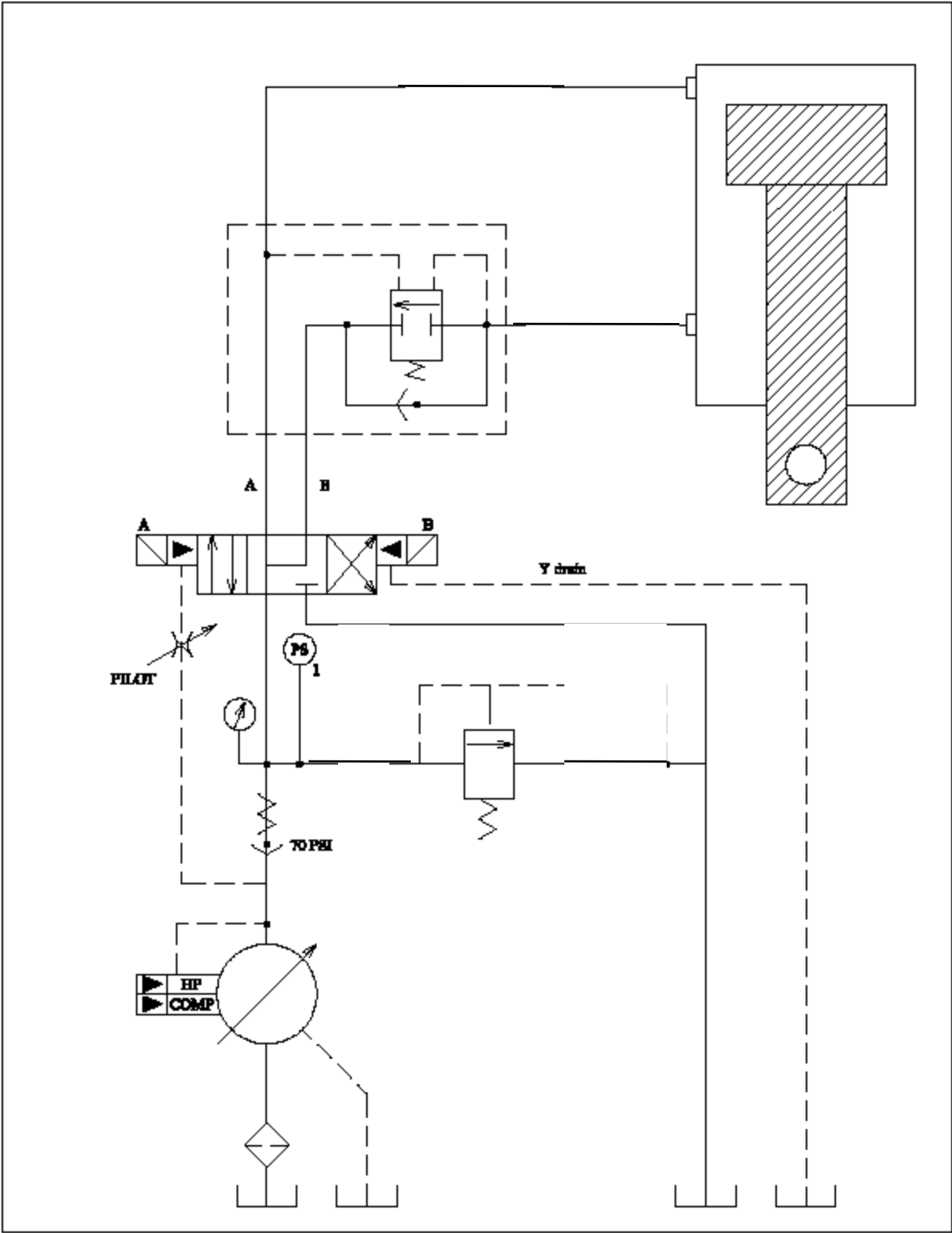

HYDRAULIC SCHEMATIC – 40HP

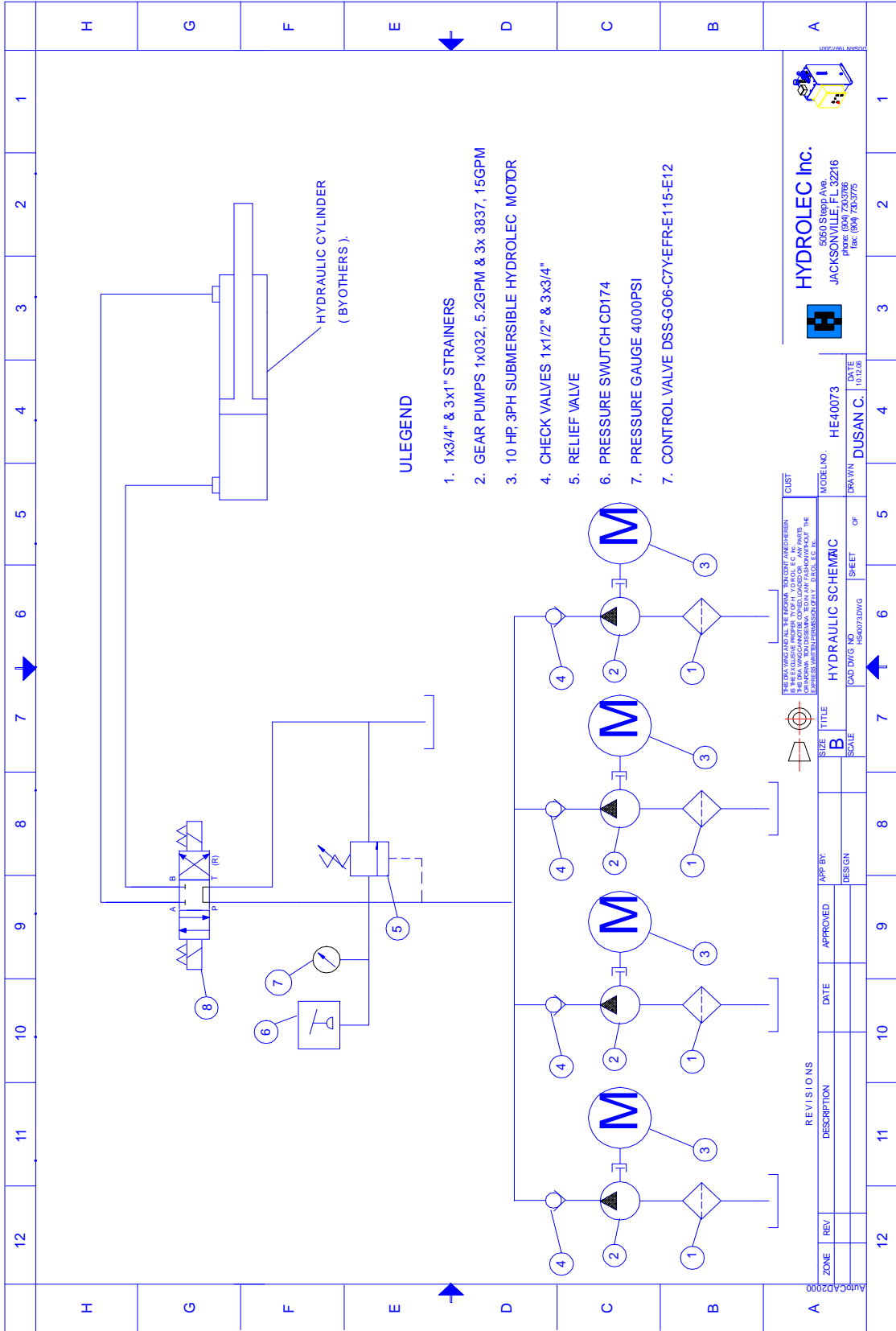

Warranty Registration

NOTICE

The installer must test each of the items indicated below and check them off as inspected in the column provided. The installer must sign in the space provided below that the tests have been completed.

Complete and mail to:

BACE, LLC

2205 North Tryon St.

Charlotte, NC 28206

*FORM MUST BE FILLED OUT AND MAILED
WITHIN 14 DAYS OF INSTALLATION*

MODEL	SERIAL NUMBER	INSTALLATION DATE	PURCHASE DATE	PURCHASED FROM

Purchasing Company _____ Contact Name _____

Address: _____ City: _____ State: _____ Zip: _____

Phone: _____ Fax: _____ Email: _____

Installer Pre-Delivery Check List:

EQUIPMENT MUST BE STORED, INSTALLED AND OPERATED IN A DRY ENVIRONMENT UNLESS OPTIONAL NEMA 4 CONTROLS ARE INSTALLED.

- Fuse disconnect and 12 ft. pigtail installed.
- Is supplied voltage compatible with baler specifications.
- Check full bale switch. (Run ram down, override full bale switch, at bottom baler should shut off)
- Check main door (door open, baler should shut off).
- Check safety gate (with baler running open safety gate and baler should stop).
- Check up stop (with platen moving up, press the UP stop switch and platen should stop).
- Check all electrical connections are tight.
- Check hydraulic level in sight glass.
- Check hydraulic hoses and fittings.
- Ejector system is ok.
- Baler is lagged down.
- Breather cap is installed.
- Safety decals in place.
- Owner/Operator has manuals, extra copies of electrical and hydraulic schematics and keys.
- Owner/Operator has been properly trained in the operation and safety features.

Installer Signature: _____ Date: _____