

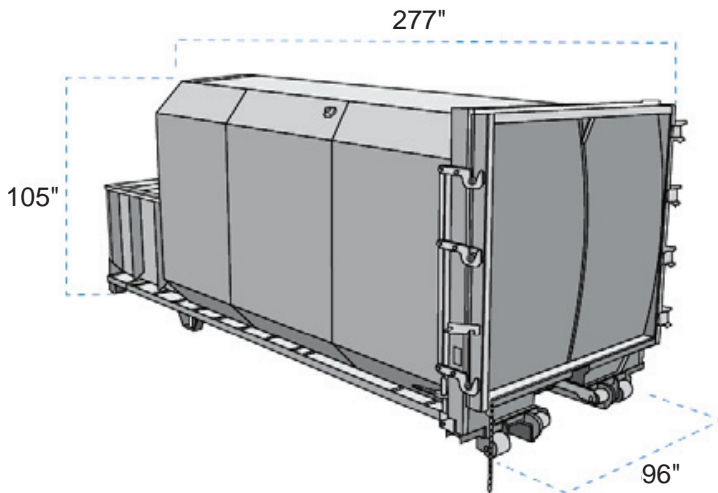

Self-Contained Compactor - SC35

Our self-contained unit is built for businesses that require the storage and removal of wet waste such as hotels, hospitals, food courts, restaurants and retail food stores.



SPECIFICATIONS	
MFG Rating CU/YD	1.51
Ram Face (H"xW")	29 x 50
Ram Penetration (in)	6
Cylinder Bore//Stroke/Rod (in)	(2) 4 x 35 x 2
Motor (HP)	10
Pump GPM	10.5
Avg. Cycle Time (sec)	48
Clear Top Opening (in)	42 x 60
Discharge Opening (in)	30 x 60
Hydraulic Pressure PSI Normal/Maximum	1800/2200
Force Rating (lb) Normal/Maximum	45,200/52,780
Approx. Compactor Shipping Weight (lbs)	10,500

CONSTRUCTION	
Charge Box Sides (in)	1/4
Charge Box Floor (in)	1/2
Ram Face (in) Charge Box Floor (in)	1/2
Ram Bottom (in)	3/8
Ram Top (in)	1/4
Breaker Bar Structural Angle	6" x 8" x 3/4"
Longsills	6" x 2" x 1/4"
Understructure Floor	7 Ga
Container Sides	7 Ga
Top	10 Ga
Door	10 Ga

Available Options
Advanced / full lights
Auto timer start
Oil heater
Ozone odor control
Fabricated options
Doghouse, Hoppers, Chute, etc.

Due to continual product improvement BACE reserves the right to change specifications without notice. The information and pictures used in the document are for illustrative purposes only.

Printed on recycled paper

M-3212009

