



Vertical Baler - V32

Our standard high density baler has an economical yet dependable design.

The V32 baler is compact and space saving without sacrificing quality and durability. It is ideal for customers with space constraints.

This model is ideal for Retailers, Grocery Stores, Drug Stores, and other organizations that recycle OCC or Plastic Film.



SPECIFICATIONS	
PERFORMANCE	
Nominal Bale Size	36" x 24" x 30"
Bale Weight	Up to 250 lbs OCC
Bale Weight Plastic Film	Up to 230 lbs
Compact Force lbs. - Normal/Maximum	12,016/14,843
Average Cycle Time	43 Seconds
Ejector System	Semi-Automatic
HYDRAULIC/ELECTRICAL	
Motor HP	2
Voltage 1 Phase (Optional 3 Phase)	110, 220 (1 ph)
Pump GPM	2.8
Normal System Pressure PSI	1700
Max. System Pressure PSI	2100
Cylinder Bore	3"
Cylinder Stroke	30"
Hydraulic Tank-Capacity Gallons	5

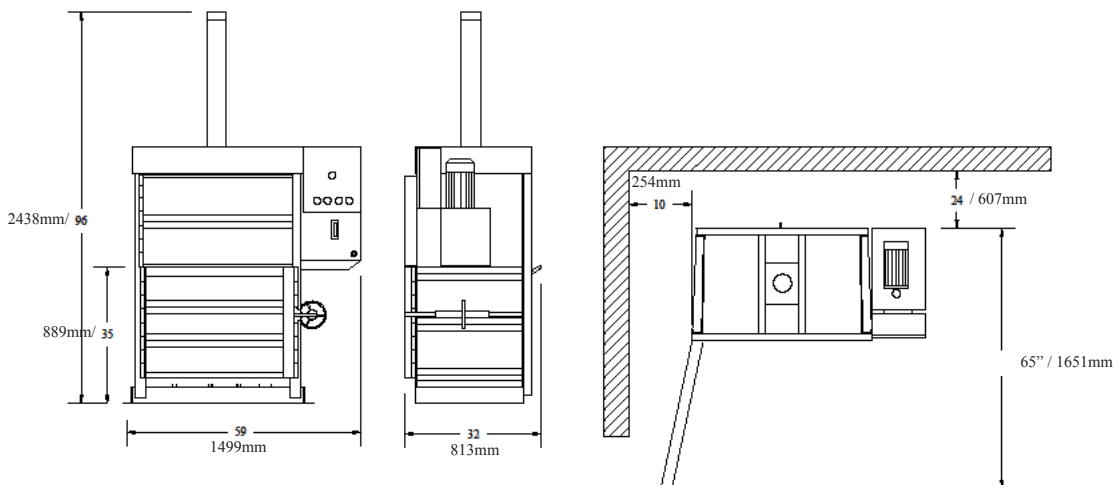

Includes:
Hydraulic Oil &
Starter Bundle of Wire

Due to continual product improvement BACE reserves the right to change specifications without notice. The information and pictures used in the document are for illustrative purposes only.

Printed on recycled paper

M-06012010

