



Vertical Baler - V43

The V43 is designed to produce high density bales while taking up minimal space.

This model comes standard with a full bale switch and is ideal for Retailers, Grocery Stores, Drug Stores, Distribution Centers, and other organizations and have space constraints.



SPECIFICATIONS	
PERFORMANCE	
Nominal Bale Size	48" x 30" x 48"
Bale Weight	Up to 800 lbs OCC
Bale Volume	40 cu.ft.
No. of Bale Tie Slots (14ft. Long x 14ga.)	4
Compact Force lbs. - Normal/Maximum	56,548/67,857
Platen Pressure	39 PSI
Average Cycle Time	37 Seconds
Loading Height	49.6"
Ejector System	Semi-Automatic
HYDRAULIC/ELECTRICAL	
Motor HP	15
Voltage 3 Phase	208, 230, 480
Pump GPM	15
Normal System Pressure PSI	2000
Max. System Pressure PSI	2400
Cylinder Bore	6"
Hydraulic Tank-Capacity Gallons	22

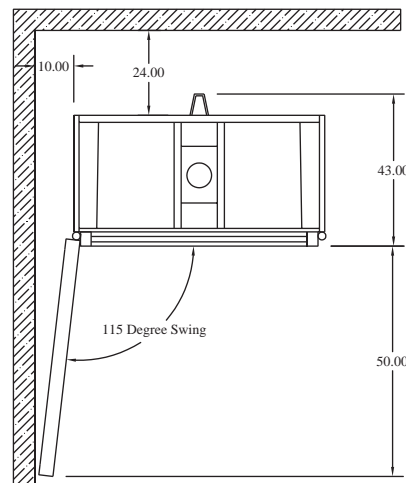
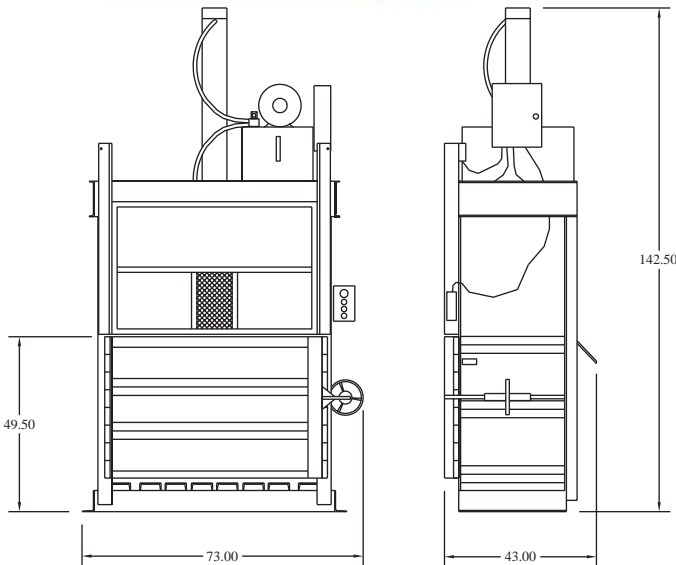

Available Options
Slotted Front Door
Wire Guides (allows for front bale tie-off)
Rear Feed Opening, Front Eject
Feed Chute
Counter Weighted Floppy Retainer Dogs
Oil Heater
Weather Proof Package
Full Bale Light

Due to continual product improvement BACE reserves the right to change specifications without notice. The information and pictures used in the document are for illustrative purposes only.

Printed on recycled paper

M-5272009



Toll Free: (877) 506-BACE (2223)
www.BACECORP.com

BACE equipment is ETL certified/UL approved and meets or exceeds ANSI standard Z245.5.

