



Vertical Baler - V43XHD

The V43XHD is designed to produce high density bales while taking up minimal space.

This model comes standard with a full bale switch and is ideal for Retailers, Grocery Stores, Drug Stores, Distribution Centers, and other organizations that have space constraints.

Includes:
Hydraulic Oil &
Starter Bundle of Wire



SPECIFICATIONS	
PERFORMANCE	
Nominal Bale Size	48" x 30" x 48"
Bale Weight	Up to 1000 lbs
Bale Volume	40 cu.ft.
No. of Bale Tie Slots	5
Compact Force lbs. - Normal/Maximum	84,667/96,213
Platen Pressure	63 PSI
Average Cycle Time	67 Seconds
Loading Height	49.50"
Ejector System	Semi-Automatic
HYDRAULIC/ELECTRICAL	
Motor HP	20
Voltage 3 Phase (V = Volts) Full Load Amps Required (A = Amps)	208V, 230V, 480V 59A, 54A, 27A
Pump GPM	15
Normal System Pressure PSI	2200
Max. System Pressure PSI	2400
Cylinder Bore	7" x 60"
Hydraulic Tank-Capacity Gallons	30

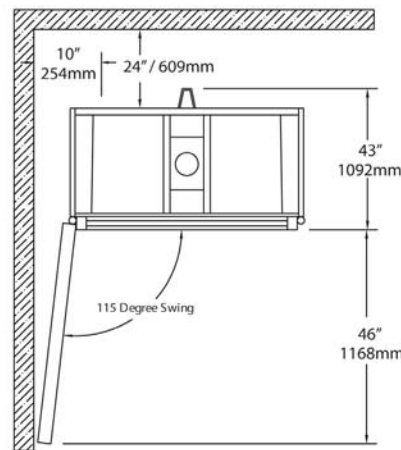
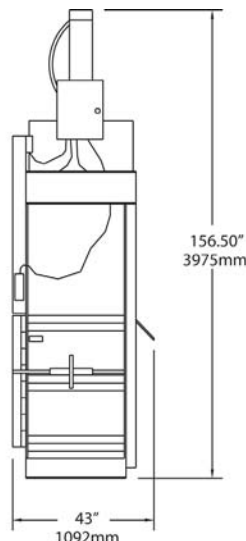
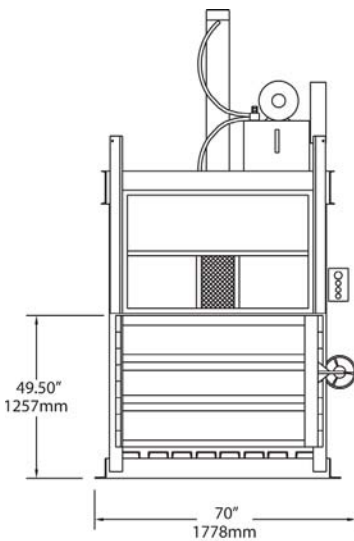

Available Options
Slotted Front Door
Wire Guides (allows for front bale tie-off)
Rear Feed Opening, Front Eject
Feed Chute
Counter Weighted Floppy Retainer Dogs
Oil Heater
Weather Proof Package
Full Bale Light

Due to continual product improvement BACE reserves the right to change specifications without notice. The information and pictures used in the document are for illustrative purposes only.

Printed on recycled paper

January 2012



Toll Free: (877) 506-BACE (2223) - Fax: (704) 394-2210
www.BACECORP.com



