



Vertical Baler - V63

Our standard V63 baler is comparable to other manufacturers' "HD" baler models.

The V63 is designed for use in retail stores, manufacturing plants, warehouses, distribution centers or any location producing refuse paper and plastic.



SPECIFICATIONS	
PERFORMANCE	
Nominal Bale Size	60" x 30" x 48"
Bale Weight	Up to 1100 lbs OCC
Bale Volume	50 cu.ft.
No. of Bale Tie Slots (14ft. Long x 14ga.)	6
Compact Force lbs. Normal/Maximum	56,548/67,857
Platen Pressure	34 PSI
Average Cycle Time	37 Seconds
Loading Height	49.6"
Ejector System	Semi-Automatic
Full Bale Switch	Standard
Approximate Baler Shipping Weight	4200 lbs
HYDRAULIC/ELECTRICAL	
Motor HP	15
Voltage 3 Phase	208, 230, 480
Pump GPM	15
Normal System Pressure PSI	2000
Max. System Pressure PSI	2400
Cylinder Bore x Stroke	6" x 48"
Hydraulic Tank-Capacity Gallons	22

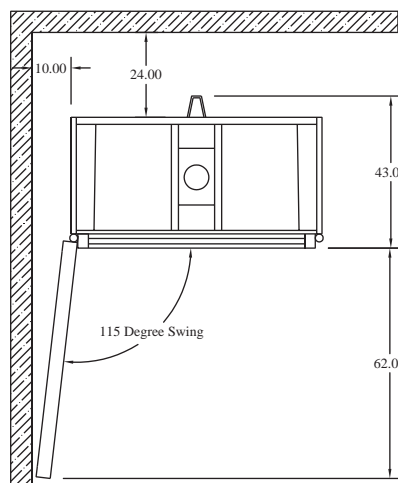
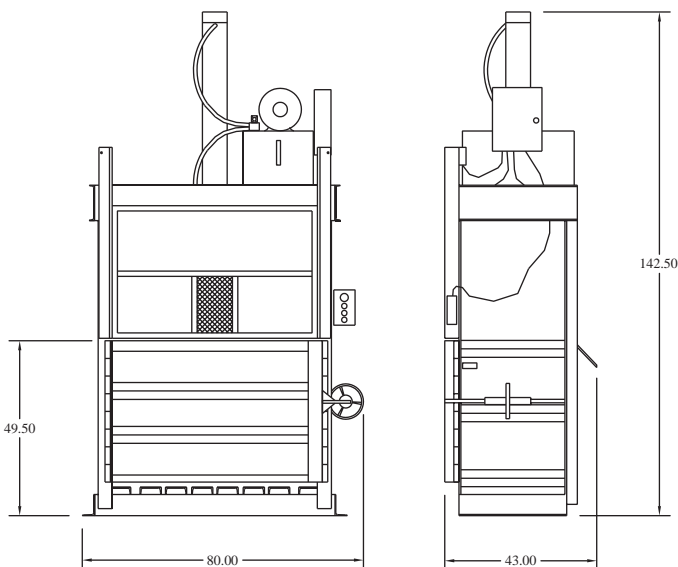

Available Options
Slotted Front Door
Wire Guides (allows for front bale tie-off)
Rear Feed Opening, Front Eject
Feed Chute
Counter Weighted Floppy Retainer Dogs
Oil Heater
Weather Proof Package
Full Bale Light

Due to continual product improvement BACE reserves the right to change specifications without notice. The information and pictures used in the document are for illustrative purposes only.

Printed on recycled paper

M-5272009

