



Vertical Baler - V63HD

Our flagship machine, the standard V63HD baler is designed for use in retail stores, manufacturing plants, warehouses, distribution centers or any location producing refuse paper and plastic.

Includes:
Hydraulic Oil & Starter Bundle of Wire



SPECIFICATIONS	
PERFORMANCE	
Nominal Bale Size	60" x 30" x 48"
Bale Weight	Up to 1100 lbs OCC
Bale Volume	50 cu.ft.
No. of Bale Tie Slots	6
Compact Force lbs. Normal/Maximum	62,202/67,857
Platen Pressure	38 PSI
Average Cycle Time	46 Seconds
Loading Height	49.50"
Ejector System	Semi-Automatic
Full Bale Switch	Standard
HYDRAULIC/ELECTRICAL	
Motor HP	15
Voltage 3 Phase	208, 230, 480
Pump GPM	12.8
Normal System Pressure PSI	2200
Max. System Pressure PSI	2400
Cylinder Bore x Stroke	6" x 48"
Hydraulic Tank-Capacity Gallons	22

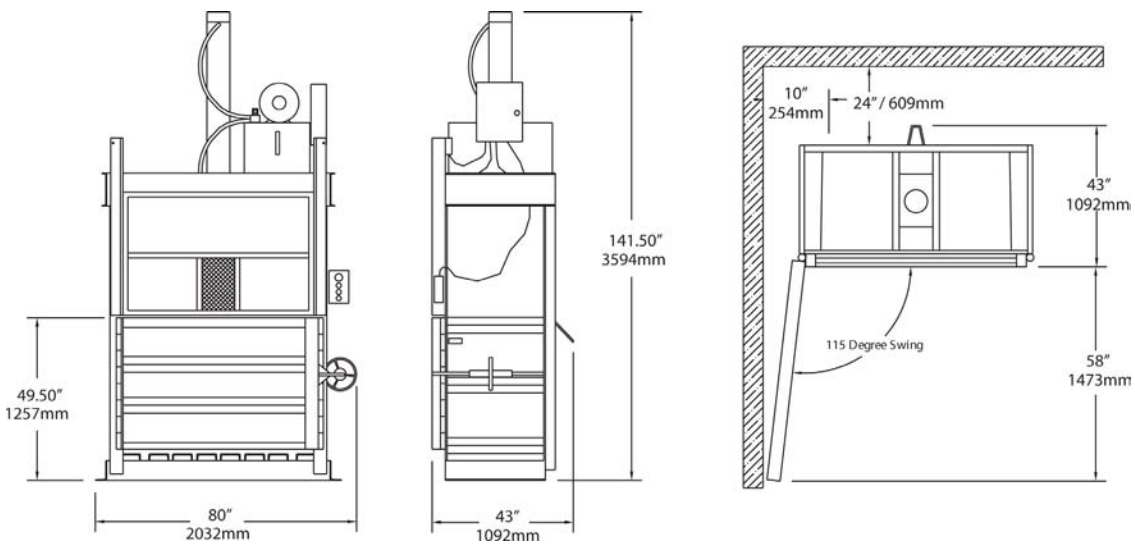

Available Options
Slotted Front Door
Wire Guides (allows for front bale tie-off)
Rear Feed Opening, Front Eject
Feed Chute
Counter Weighted Floppy Retainer Dogs
Oil Heater
Weather Proof Package
Full Bale Light

Due to continual product improvement BACE reserves the right to change specifications without notice. The information and pictures used in the document are for illustrative purposes only.

Printed on recycled paper

M-06012010

