



Vertical Baler - V630CC

Our standard high density baler has an economical yet dependable design.

The V630CC baler is configured for generating mill size, marketable bales of corrugated materials (OCC) while controlling equipment cost.

This model is ideal for Retailers, Grocery Stores, Drug Stores, and other organizations that recycle OCC.



| SPECIFICATIONS | |
|---|-----------------------------------|
| PERFORMANCE | |
| Nominal Bale Size | 60" x 30" x 48" |
| Bale Weight | Up to 1000 lbs OCC |
| Bale Volume | 50 cu.ft. |
| No. of Bale Tie Slots | 6 |
| Compact Force lbs. - Normal/Maximum | 56,548/62,202 |
| Platen Pressure | 34 PSI |
| Average Cycle Time | 48 Seconds |
| Loading Height | 49.50" |
| Ejector System | Semi-Automatic |
| HYDRAULIC/ELECTRICAL | |
| Motor HP | 10 |
| Voltage 3 Phase (V = Volts) Full Load Amps Required (A = Amps) | 208V, 230V, 480V 30A, 28A, 14A |
| Pump GPM | 10.5 |
| Normal System Pressure PSI | 2000 |
| Max. System Pressure PSI | 2200 |
| Cylinder Bore | 6" |
| Hydraulic Tank-Capacity Gallons | 22 |

This model is available with a 10HP-Submersible Power Unit. Call for details.

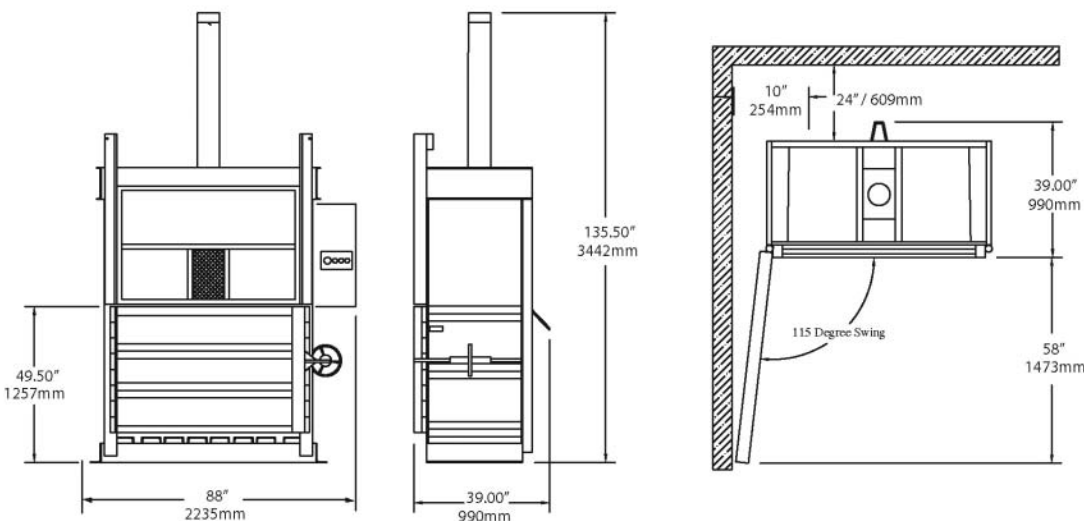

Includes:
Hydraulic Oil &
Starter Bundle of Wire

Due to continual product improvement BACE reserves the right to change specifications without notice. The information and pictures used in the document are for illustrative purposes only.

Printed on recycled paper

January 2012



