

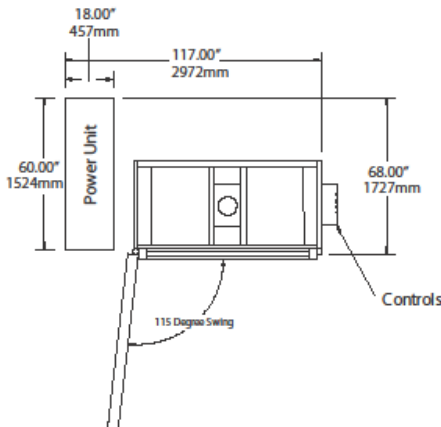

Extra Heavy Duty Vertical Baler - V73-865

This baler can produce bale weights in excess of 1,500 lbs of cardboard and 2,200 lbs of non-ferrous metal.

Our extra heavy-duty baler is designed for high capacity requirements, providing a compact force up to 150,000 lbs.

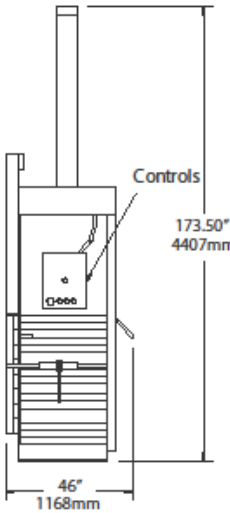
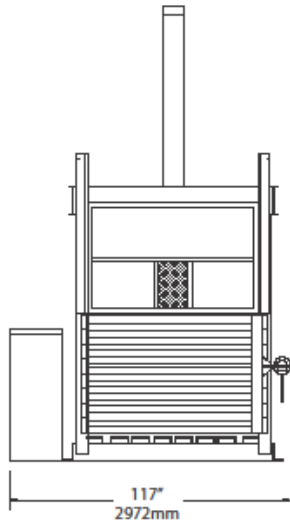

Includes:
Hydraulic Oil & Starter Bundle of Wire

Due to continual product improvement BACE reserves the right to change specifications without notice. The information and pictures used in the document are for illustrative purposes only.

Printed on recycled paper

M-06012010

SPECIFICATIONS	
PERFORMANCE	
Nominal Bale Size	72" x 30" x 48"
Bale Weight	Up to 1700 lbs OCC
Bale Volume	60 cu.ft.
No. of Bale Tie Slots	7
Compact Force lbs.	150,000
Platen Pressure	75 PSI
Average Cycle Time	35 Seconds
Loading Height	54"
Ejector System	Semi-Automatic
Full Bale Light	Standard

OPTION 1: HYDRAULIC/ELECTRICAL	
40HP Submersible Power Unit	4-10HP Motors
Voltage 3 Phase	208, 230, 480
Pump GPM	47
Normal System Pressure PSI	3000
Cylinder Bore	8"
Cylinder Stroke	65"
Hydraulic Tank-Capacity Gallons	100

OPTION 2 HYDRAULIC/ELECTRICAL	
20HP Conventional Power Unit	20HP Motor
Voltage 3 Phase	208, 230, 480
Pump (HP Limiting)	33 GPM (Pres. Comp.)
Normal System Pressure PSI	3000
Max. System Pressure PSI	3500
Cylinder Bore	8"
Cylinder Stroke	65"
Hydraulic Tank-Capacity Gallons	80

ELECTRICAL REQUIREMENT NOTES:			
Motor HP	Voltage	Full Load Amps	Power Supply Required
40HP (4-10HP Motors)	208V	30.8/Motor	150 Amp
40HP (4-10HP Motors)	230V	28/Motor	150 Amp
40HP (4-10HP Motors)	460/480V	14/Motor	100 Amp
20 HP	208V	47.6	100 Amp
20 HP	230V	47.6	100 Amp
20 HP	460/480V	23.8	50 Amp

