



## Vertical Baler - V73HD

Our standard V73HD features a 15 HP High Efficiency-Power Unit.

When the opening of a standard size Vertical Baler is not quite big enough, the V73HD is the design of choice. When the baler footprint is less of a concern and large bale sizes/weights are more of a priority, this baler is the right choice.

This model is ideal for Retailers, Grocery Stores, Drug Stores, and other organizations.



**Includes:**  
Hydraulic Oil &  
Starter Bundle of Wire

### SPECIFICATIONS

| PERFORMANCE                       |                    |
|-----------------------------------|--------------------|
| Nominal Bale Size                 | 72" x 30" x 48"    |
| Bale Weight                       | Up to 1300 lbs OCC |
| Bale Volume                       | 60 cu.ft.          |
| No. of Bale Tie Slots             | 7                  |
| Compact Force lbs. Normal/Maximum | 62,202 / 67,857    |
| Platen Pressure                   | 30 PSI             |
| Average Cycle Time                | 46 Seconds         |
| Loading Height                    | 49.50"             |
| Ejector System                    | Semi-Automatic     |
| Full Bale Switch                  | Standard           |
| HYDRAULIC/ELECTRICAL              |                    |
| Motor HP                          | 15                 |
| Voltage 3 Phase                   | 208, 230, 480      |
| Pump GPM                          | 12.8               |
| Normal System Pressure PSI        | 2200               |
| Max. System Pressure PSI          | 2400               |
| Cylinder Bore x Stroke            | 6" x 48"           |
| Hydraulic Tank-Capacity Gallons   | 22                 |

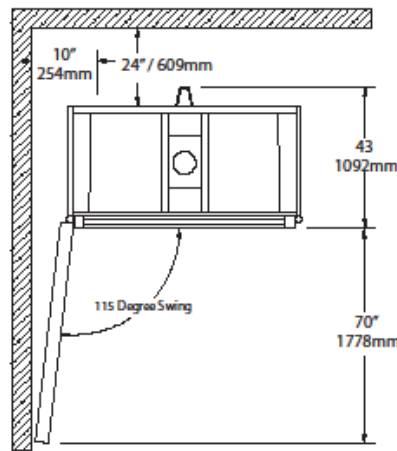
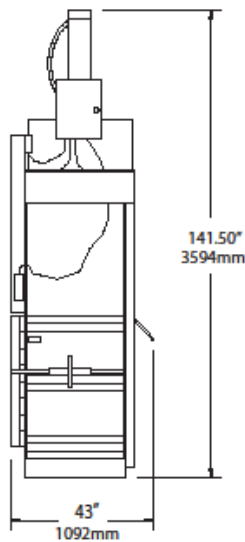
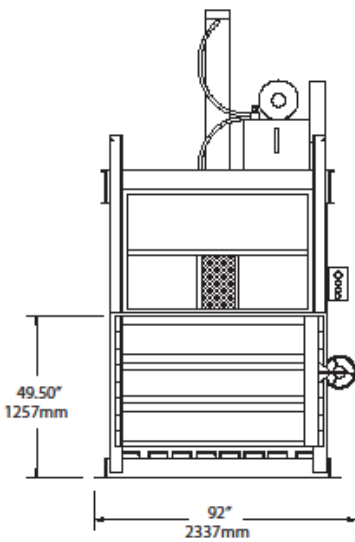

### Available Options

- Slotted Front Door
- Wire Guides (allows for front bale tie-off)
- Rear Feed Opening, Front Eject
- Feed Chute
- Counter Weighted Floppy Retainer Dogs
- Oil Heater
- Weather Proof Package
- Full Bale Light

Due to continual product improvement BACE reserves the right to change specifications without notice. The information and pictures used in the document are for illustrative purposes only.

Printed on recycled paper

M-06012010



Toll Free: (877) 506-BACE (2223) - Fax: (704) 394-2210  
www.BACECORP.com

