



Vertical Baler - V73XHD

When the baler footprint is less of a concern and large bale sizes and weights are more of a priority, this baler is the right choice. With its wide opening, 20HP motor and deep penetration 7" bore cylinder the V73XHD will produce extremely dense bales of paper, plastic and non-ferrous metal.

Includes:
Hydraulic Oil &
Starter Bundle of Wire



SPECIFICATIONS	
PERFORMANCE	
Nominal Bale Size	72" x 30" x 48"
Bale Weight	Up to 1400 lbs OCC
Bale Volume	60 cu.ft.
No. of Bale Tie Slots	7
Compact Force lbs. Normal/Maximum	84,667/96,213
Platen Pressure	43 PSI
Average Cycle Time	67 Seconds
Loading Height	49.50"
Ejector System	Semi-Automatic
Full Bale Switch	Standard
HYDRAULIC/ELECTRICAL	
Motor HP	20
Voltage 3 Phase	208, 230, 480
Pump GPM	15
Normal System Pressure PSI	2200
Max. System Pressure PSI	2500
Cylinder Bore x Stroke	7" x 60"
Hydraulic Tank-Capacity Gallons	30

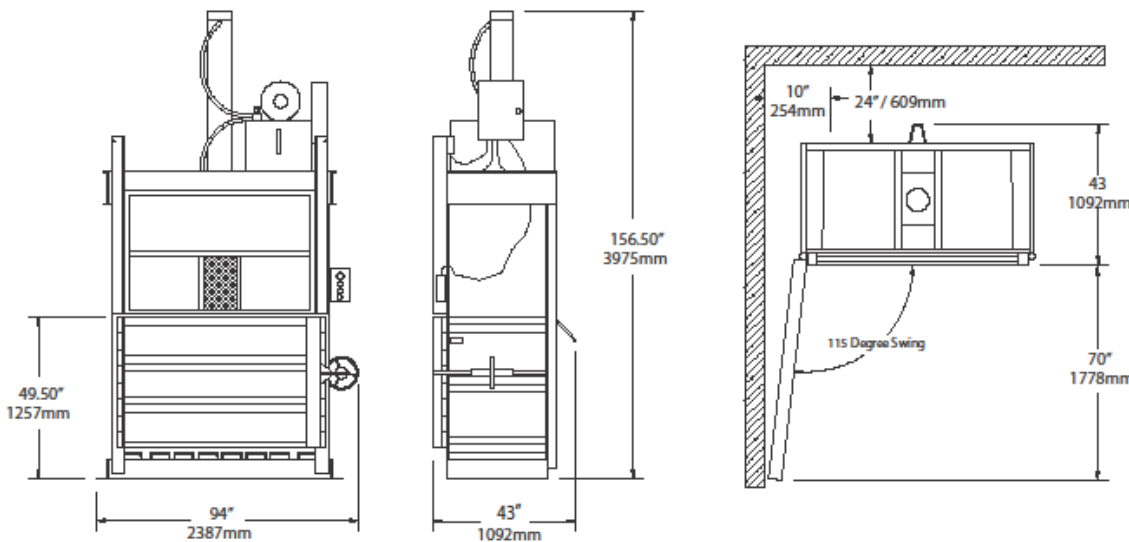

Available Options
Slotted Front Door
Wire Guides (allows for front bale tie-off)
Rear Feed Opening, Front Eject
Feed Chute
Counter Weighted Floppy Retainer Dogs
Oil Heater
Weather Proof Package
Full Bale Light

Due to continual product improvement BACE reserves the right to change specifications without notice. The information and pictures used in the document are for illustrative purposes only.

Printed on recycled paper

M-06012010

