

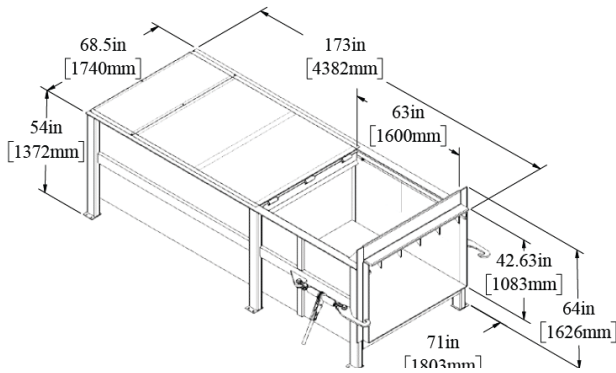

# BACE

## BACE Stationary Compactor C2S

For heavy commercial and light industrial applications, the C2S model is designed for durability and long life. The BACE heavy duty units are built with massive structural reinforcement in the breaker bar and charge box areas.



### Available Options

- Advanced / Full Lights
- Auto Timer Start
- Doghouse, Hoppers, Chute, etc.
- Fabricated Options
- Oil Heater
- Ozone Odor Control

**Order Today: (877) 506-BACE**  
or visit us online at [www.bacecorp.com](http://www.bacecorp.com)

322 West 32nd Street  
Charlotte, NC. 28206

*BACE Vertical Balers meet or exceed all existing ANSI & OSHA Safety Standards and are totally 100% ETL & CETL Approved.*



**LEARN MORE AT [WWW.BACECORP.COM](http://WWW.BACECORP.COM)**

Toll Free: (877) 506-BACE (2223) • Fax: (704) 394-2210  
BACE equipment meets or exceeds ANSI standard Z245.5.

# BACE Stationary Compactor C2S

## SPECIFICATIONS

### PERFORMANCE

|   |                 |
|---|-----------------|
| MFG Rating CU/YD                        | 2               |
| Ram Face (H"xW")                        | 30 x 60         |
| Ram Penetration (in)                    | 6               |
| Cylinder Bore//Stroke                   | 2X - 4 x 32     |
| Motor (HP)                              | 10              |
| Pump GPM                                | 10.5            |
| Avg. Cycle Time (sec)                   | 40              |
| Clear Top Opening (in)                  | 40 x 60         |
| Discharge Opening (in)                  | 37 x 60         |
| Hydraulic Pressure PSI Normal/Maximum   | 1800 / 2200     |
| Force Rating (lb) Normal/Maximum        | 45,241 / 55,294 |
| Approx. Compactor Shipping Weight (lbs) | 4500            |

### CONSTRUCTION

|                              |                |
|------------------------------|----------------|
| Charge Box Sides (in)        | 3/16           |
| Charge Box Floor (in)        | 1/2            |
| Ram Face (in)                | 3/8            |
| Ram Bottom (in)              | 3/8            |
| Ram Top (in)                 | 1/4            |
| Breaker Bar Structural Angle | 4" x 6" x 3/4" |

ADDITIONAL HYDRAULIC/ELECTRICAL CONFIGURATIONS ARE AVAILABLE. PLEASE CALL BACE FOR MORE INFORMATION.

*Due to continual product improvement BACE reserves the right to change specifications without notice.*

*The information and pictures used in the document are for illustrative purposes only.*

*Printed on recycled paper.*