

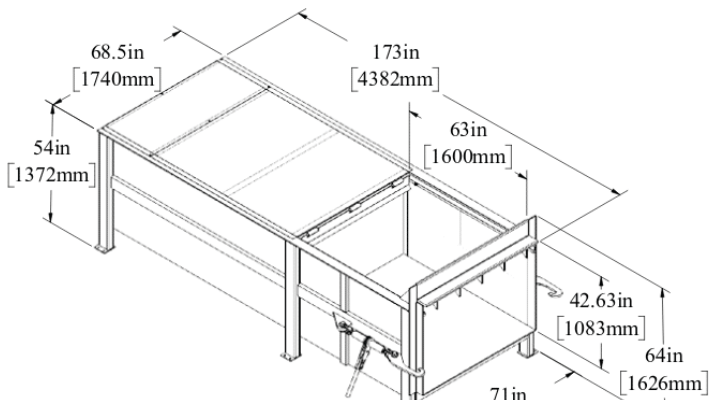

# BACE

## BACE Stationary Compactor C4

Exceptional quality and design make the C4 the right choice for those large commercial and industrial applications. The large charge box opening allows easy loading of bulky items such as drums, pallets, crates and general industrial discards.



### Available Options

- Advanced / Full Lights
- Auto Timer Start
- Doghouse, Hoppers, Chute, etc.
- Fabricated Options
- Oil Heater
- Ozone Odor Control

**Order Today: (877) 506-BACE**  
or visit us online at [www.bacecorp.com](http://www.bacecorp.com)

322 West 32nd Street  
Charlotte, NC. 28206

*BACE Vertical Balers meet or exceed all existing ANSI & OSHA Safety Standards and are totally 100% ETL & CETL Approved.*



**LEARN MORE AT [WWW.BACECORP.COM](http://WWW.BACECORP.COM)**

Toll Free: (877) 506-BACE (2223) • Fax: (704) 394-2210  
BACE equipment meets or exceeds ANSI standard Z245.5.

# BACE Stationary Compactor C4

## SPECIFICATIONS

### PERFORMANCE

MFG Rating CU/YD	4
Ram Face (H"xW")	36 x 60
Ram Penetration (in)	14
Cylinder Bore//Stroke/Rod (in)	6 x 79 x 4
Motor (HP)	20
Pump GPM	15
Avg. Cycle Time (sec)	63
Clear Top Opening (in)	60 x 63
Discharge Opening (in)	41 x 60
Hydraulic Pressure PSI Normal/Maximum	1800 / 2200
Force Rating (lb) Normal/Maximum	50,893 / 62,203
Approx. Compactor Shipping Weight (lbs)	4500

### CONSTRUCTION

Charge Box Sides (in)	1/4
Charge Box Floor (in)	1/2
Ram Face (in)	1/2
Ram Bottom (in)	1/2
Ram Top (in)	1/4
Breaker Bar Structural Angle	6" x 8" x 1"

ADDITIONAL HYDRAULIC/ELECTRICAL CONFIGURATIONS ARE AVAILABLE. PLEASE CALL BACE FOR MORE INFORMATION.

*Due to continual product improvement BACE reserves the right to change specifications without notice.*

*The information and pictures used in the document are for illustrative purposes only.*

*Printed on recycled paper.*