



BACE

BACE Vertical Baler V63XHD

This baler is full of features the others can't touch. Its 7" cylinder with a 60" stroke makes it the unit of choice for numerous recycling and distribution centers with high volumes or tough materials. It outperforms all comparable balers and is considered by many to be the best value in the industry.

Ideal for

- Big Box Retailers
- National Accounts
- Commissaries
- Pharmacies
- Distribution Centers
- Recyclers
- Grocery Stores
- Schools
- Home Retailers
- Universities
- Hospitals
- Warehouses



Order Today: (877) 506-BACE
or visit us online at www.bacecorp.com

322 West 32nd Street
Charlotte, NC. 28206

*BACE Balers meet existing ANSI Standards
and are ETL & CETL Approved.*



LEARN MORE AT WWW.BACECORP.COM
Toll Free: (877) 506-BACE (2223) • Fax: (704) 394-2210

BACE Vertical Baler V63XHD

DIM. (in./mm)

- A. 49.5/1257
- B. 91.5/2324
- C. 43/1143
- D. 156/3975
- E. 98/2489

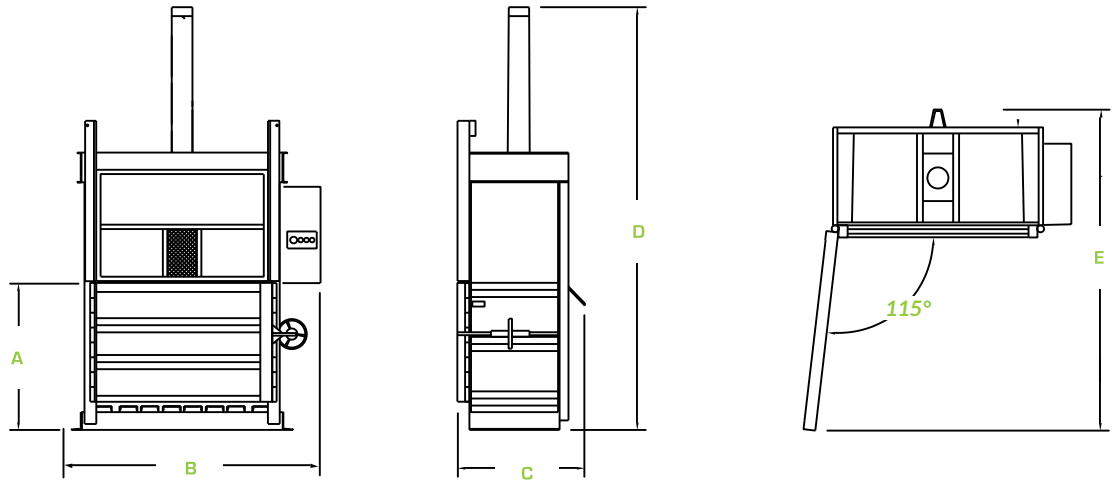

SPECIFICATIONS

PERFORMANCE

Nominal Bale Size	60" x 30" x 48"
Bale Weight	Up to 1300 lbs OCC
Bale Volume	50 cu. ft.
No. of Bale Tie Slots	5
Compact Force lbs - Normal / Maximum	84,667
Average Cycle Time	70 Seconds
Loading Height	49.50"
Full Bale Switch	Standard

HYDRAULIC / ELECTRICAL

Motor HP	10 HP Submersible
Voltage 3 Phase	208V, 230V, 480V
Full Load Amps (A = Amps)	32A, 28A, 14A
Pump GPM	14/4
Normal System Pressure PSI	2200
Cylinder Bore x Stroke	7" x 60"
Hydraulic Tank-Capacity Gallons	40

ADDITIONAL HYDRAULIC/ELECTRICAL CONFIGURATIONS ARE AVAILABLE. PLEASE CALL BACE FOR MORE INFORMATION.

Available Options

- Slotted Front Door
- Wire Guides (allows for front bale tie-off)
- Rear Feed Opening, Front Eject
- Feed Chute
- Counter Weighted Floppy Retainer Dogs
- Oil Heater
- Weather Proof Package

Due to continual product improvement BACE reserves the right to change specifications without notice.

The information and pictures used in the document are for illustrative purposes only.

Printed on recycled paper.